

# BLUE THUNDER VARIABLE SPEED PUMP

## INSTRUCTION MANUAL



**READ THIS MANUAL CAREFULLY BEFORE USING  
YOUR BLUE THUNDER VARIABLE SPEED PUMP**

# BLUE THUNDER VARIABLE SPEED PUMP PARTS BREAKDOWN

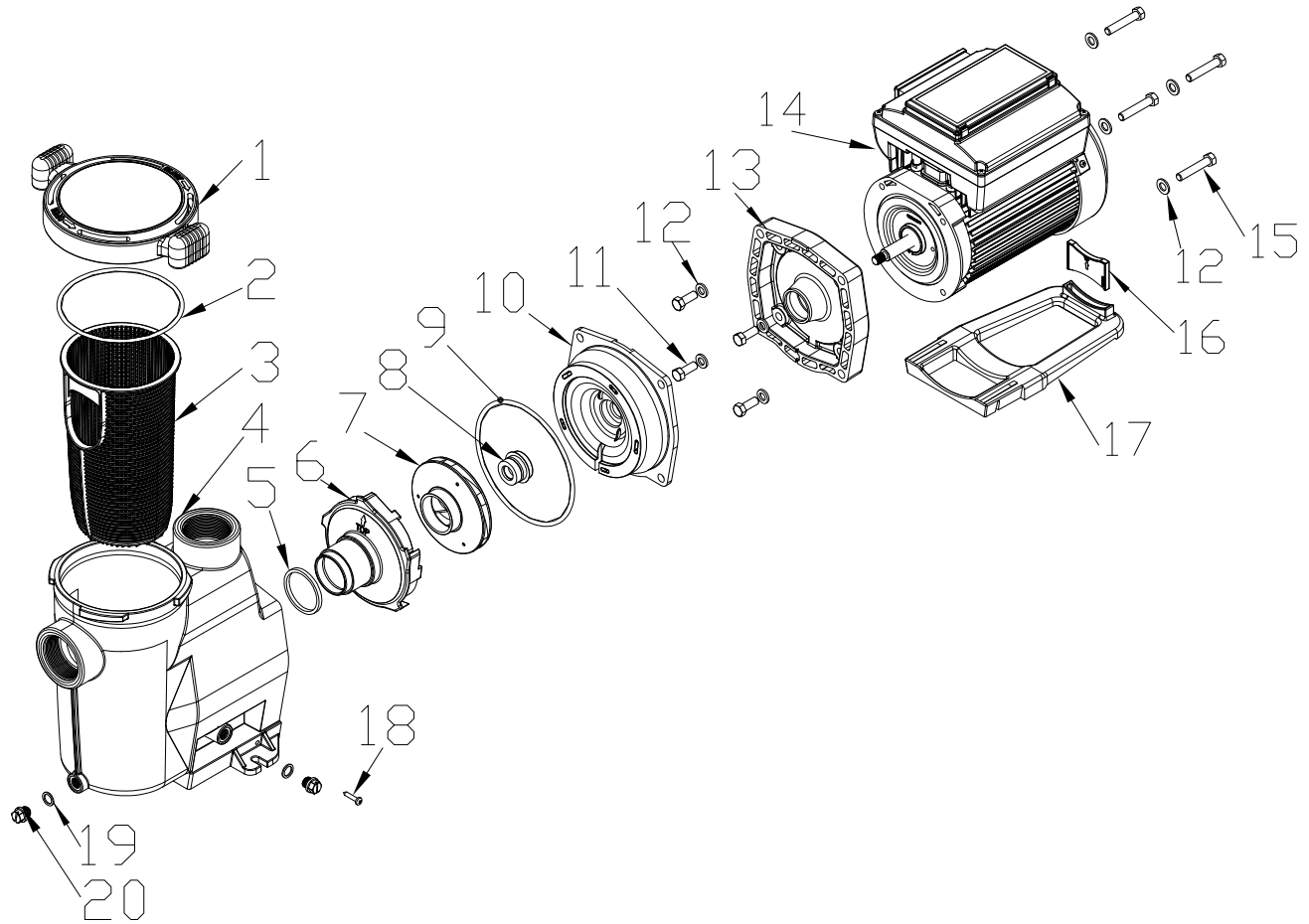

PART #	MODEL #	DESCRIPTION	QTY
1	AC 81361	Lid	1
2	AC 81396	O-Ring	1
3	AC 31887	Basket	1
4	AC 32816	Strainer Housing	1
5	AC 32824	O-Ring	1
6	AC 23493	Diffuser	1
7	AC 23523	Impeller	1
8	AC 23531	Seal Assembly	1
9	AC 23558	O-Ring	1
10	AC 23566	Flange	1
11	AC 23574	Screw	4
12	AC 82597	Washer	8
13	AC 23582	Cover	1
14	N/A	Variable Motor	1
15	AC 23590	Bolt	4
16	AC 32832	Adjust Foot	1
17	AC 23639	Bottom Brace	1
18	AC 81914	Screw	2
19	AC 81590	Gasket	2
20	AC 81620	Drain Plug	2

## IMPORTANT SAFETY INSTRUCTIONS

**NOTE** All wiring should be done by a qualified electrician in accordance to the National Electric Code and all Local Codes and ordinances.

When installing and using this electrical equipment, basic safety precautions should ALWAYS be followed.

## READ AND FOLLOW ALL INSTRUCTIONS



### WARNING

1. To reduce the risk of injury, do not allow children to use this equipment
2. Connect only to a grounding type receptacle that is protected by a ground fault circuit interrupter (GFCI).
3. Do not connect this equipment to an extension cord. To reduce the risk of electric shock, only connect the electric cord to a properly located outlet.
4. To reduce the risk of shock, connect ground wires to the grounding screw located in the motor.
5. To reduce the risk of shock, a bonding connector is provided for bonding to any metal within 5 feet of the swimming pool. All local points should be bonded with #8AWG (8.4mm<sup>2</sup>) wire.

**NOTE** To installer and/or operator of the swimming pool pump: the manufacturer's warranty will be void if the pump is improperly installed and/or operated.

## OPERATION AND MAINTENANCE

### PUMP LOCATION

1. Locate the pump on a level surface as close to the pool as practical. Consult local codes for minimum distances between pool and pump if applicable.
2. The connection plumbing (hose or rigid pipe) should be direct and as free from turns and bends as possible. Take care not to kink flexible hose. Elbows and other fittings greatly increase friction losses.
3. Place pump on a solid foundation / base which provides a rigid and vibration free support.
4. Protect the pump against flooding and excess moisture. Protect the motor from foreign objects clogging the air circulation around the motor.
5. **NEVER** use gasoline or other flammable liquids or vapors in the vicinity of this pump.

**NOTE** DO NOT store pool chemicals near this pump.  
DO NOT remove any safety labels such as CAUTION / DANGER / WARNING from this pump. Keep labels in good condition and replace any damaged labels.



## WARNING

Keep labels in good condition and replace any damaged labels

## PUMP INSTALLATION

1. When connecting plumbing fittings to the pumps threaded ports, it is recommended that thread seal tape (Teflon tape) be used. If the suction (intake) connection is not sealed correctly the pump will not prime properly and will pump only small volumes of water or no water at all.
3. Suction and discharge lines should be independently supported at a point near the pump to avoid strains being placed on the pump.
4. It is advisable to install a union in both the suction and discharge lines in the event the pump needs servicing or removal.
5. Before starting the pump for the first time remove the clear lid at the front of the pump. Fill the pump strainer with water until it is level with the suction port opening. Replace the lid making sure the lid is tight Hand tighten only.
6. **BONDING:** as required by the National Electrical Code Article 680-26 the pump must be electrically bonded to the pool structure by a solid copper conductor no smaller than #8 AWG via the external copper bonding lug on the motor.
7. **GROUNDING:** Permanently ground the pump motor using a conductor of appropriate size. Connect to the green headed screw provided inside the motor terminal box.

**NOTE DO NOT CONNECT MOTOR TO THE ELECTRIC POWER SUPPLY UNTIL IT IS PERMANENTLY GROUNDED.**

## **PUMP MAINTENANCE**

- The pump requires little to no maintenance other than reasonable care and cleaning of the strainer basket on a regular basis. The pump is equipped with a mechanical seal. This seal may eventually come loose of a period of time, depending on running time and water quality. If water continually leaks out, a new mechanical seal should be installed.
- The pump is equipped with a rubber gasket that seals the strainer basket lid. This gasket should be lubricated with water proof lubricant (O-RING LUBE) to ensure proper seal and extend gasket life.

## **WINTERIZATION**

- In areas subject to freezing temperatures, it is recommended that the pump be disconnected and stored indoors in a warm and dry location. Remove the drain plugs from the pump housing and place them in the strainer basket for storage.

## **ABOUT YOUR VARIABLE SPEED PUMP**

This variable speed pump is designed to operate your swimming pool filtration system as well as your spa, waterfall, cleaner, heater, salt chlorine system and other water applications. Using the control panel, you can run your pump on one of the four preset speeds or you can adjust the pump to run at an alternate speed. The built in advanced energy conservation features of the Variable Speed pump ensures that your filter system will operate at peak efficiency.

The Variable speed pump can run at up to eight speeds that can be adjusted to run at specific time intervals. The Blue Torrent Variable Speed pump out performs all conventional pumps in its class. The pump can operate at speeds as low as 450 RPM and as high as 3450 RPM. The pump has four factory preset speeds of 750 RPM, 1500 RPM, 2500 RPM and 3100 RPM.

The preset speeds can be selected using the pumps control panel and by pressing speed 1, speed 2, speed 3 or speed 4. The control panel also has LED indicators for speed as well as alarm indicators and error messages to warn the user against under and over voltage, high temperature, over current and freeze protection.

The pump drive assembly of your Variable Speed pump consists of a control panel and the system electronics that drive the motor. The drive microprocessor controls the motor by changing the frequency of the current it receives in addition to changing the voltage to control the rotational speed, this system enable to pump to deliver unsurpassed energy efficiency.

## **VARIABLE SPEED MOTOR FEATURES:**

- Permanent Magnet Synchronous Motor (PMSM)
- High efficiency – 92% at 3450 RPM – 86% at 1000RPM
- Superior speed control
- Low operating temperatures due to energy efficiency
- Totally enclosed and fan cooled
- Extremely quiet operation

# CONTROL AND LED'S

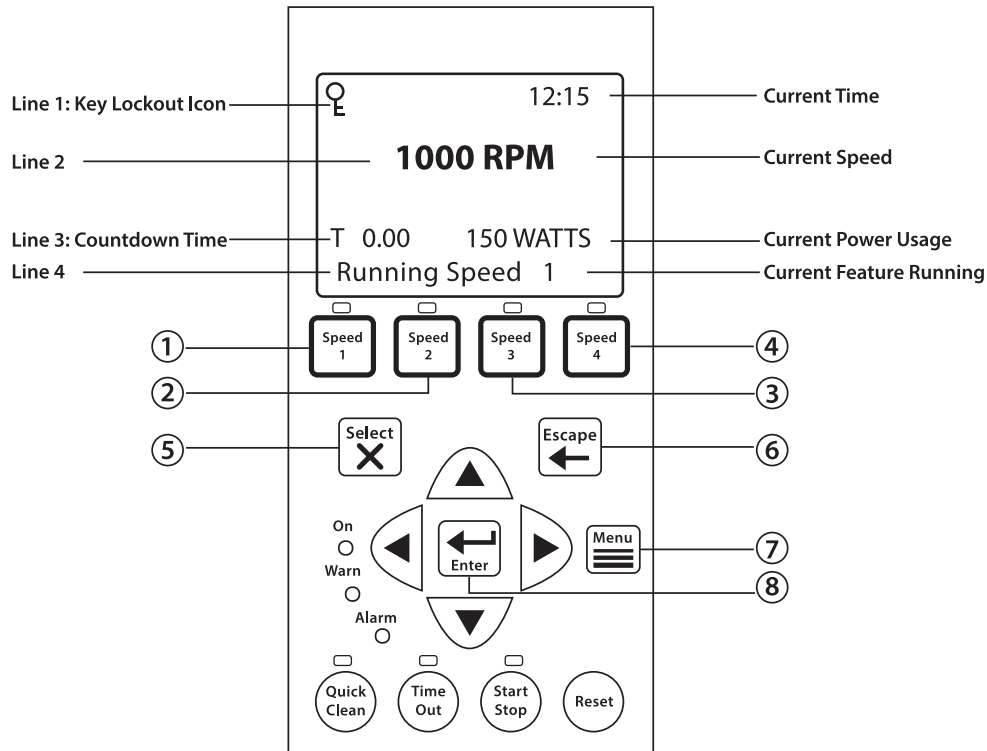

1. **SPEED 1 BUTTON / LED** – Press to select speed 1 ( 750 RPM) . The LED above the button indicates Speed 1 is active
2. **SPEED 2 BUTTON / LED** – Press to select speed 2 ( 1500 RPM). The LED above the button indicates Speed 2 is active.
3. **SPEED 3 BUTTON /LED** – Press to select speed 3 (2500 RPM). The LED above the button indicates Speed 3 is active
4. **SPEED 4 BUTTON / LED** – Press to select speed 4 (3100 RPM). The LED above the button indicates Speed 4 is active.
5. **SELECT BUTTON** – Displays available menu items or enters edit mode for changing the value on line 2 of the display
6. **ESCAPE BUTTON** – Moves to next level up in the menu structure, and / or stops editing the current setting.
7. **MENU BUTTON** – Accesses the pump menu if the pump is stopped
8. **ENTER BUTTON** – Saves the current menu item setting. Press this button to acknowledge alarms and warning alerts.
9. **ARROW BUTTONS:**
  - **UP ARROW** – Move up one level in the menu or to increase a digit when changing a setting
  - **DOWN ARROW** – Move one level down in the menu or to decrease a digit when changing a setting.
  - **LEFT ARROW** – Moves the cursor left one digit when changing a setting
  - **RIGHT ARROW** – Moves the cursor right one digit when changing a setting



10. **QUICK CLEAN** – Press Quick Clean and the pump will run at a preset speed and duration then resume current program speed. Used for vacuuming and pool maintenance
11. **TIME OUT** – When active – LED on- at the end of a “time out” preset time, the pump will run a schedule.
12. **START/STOP** – Press to start or stop the pump. When the LED is on, the pump is currently running or in a mode to start automatically
13. **RESET BUTTON** – Press to reset alarm or alert

## LED'S

- **ON** – This green power LED is on when the pump is powered on
- **WARNING** – This LED is on if a warning condition exists
- **ALARM** – This RED LED is on if an alarm condition exists.

## CONTROL PANEL LCD

- LINE 1** – Key icon indicates password protect mode is active. If password protect has not been enabled no key icon will be displayed
- LINE 2** – Displays to current pump speed ( RPM)
- LINE 3** – Count down time and Watts
- LINE 4** – Current pump status

## OPERATING THE PUMP

### STARTING THE PUMP:

1. Be sure pump is powered on and the GREEN power LED is on.
2. Select one of the four speed buttons

### STOPPING THE PUMP

1. Press the STOP button to stop the pump

### SERVICING EQUIPMENT – WARNING

When servicing equipment – filters, heaters, chlorinators, etc.- Switch off the circuit breaker to the pump BEFORE you start servicing .

## OPERATING THE VARIABLE SPEED PRESETS

To operate the Pump at one of the four preset speeds:

1. Be sure the pump is powered on and the green power **LED** is on.
2. Press the **SPEED** button (1-4) corresponding to the desired preset speed, and release quickly. The **LED** above the speed button pressed will come on.
3. Press the **START** button. The pump will quickly ramp up to the selected preset speed.

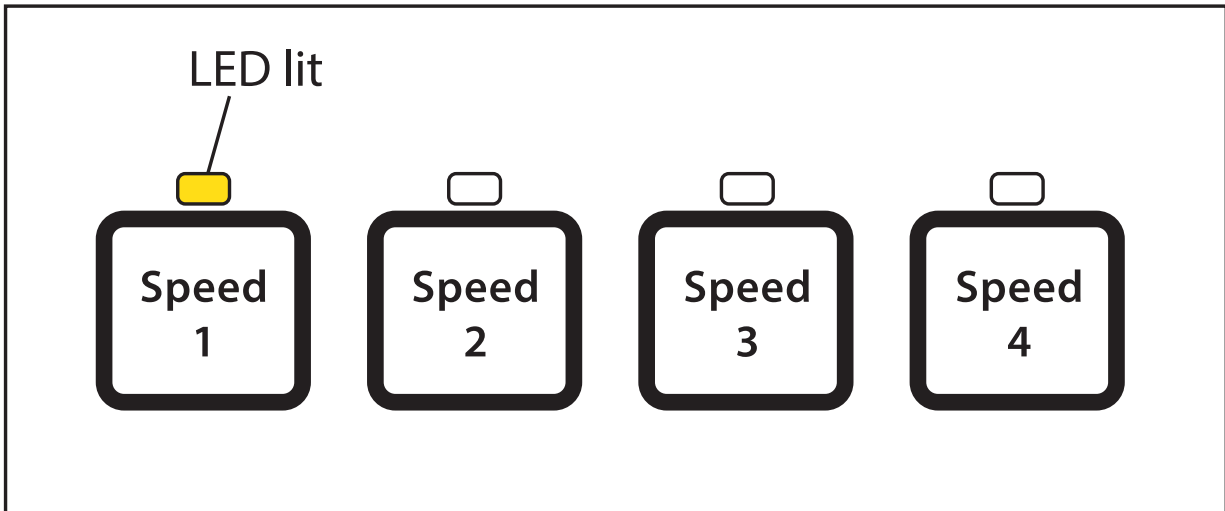

### Adjusting the speed

1. With the pump running, press the **UP ARROW** to increase speed setting
2. Press the **DOWN ARROW** to decrease speed setting
3. Press the **ENTER** button to save the speed.

## PUMP OPERATING MODES

The Variable Speed Pump can be programmed three ways:

**MANUAL OPERATION:** Speed buttons 1-4 can be programmed for manual operation. This means the speed button is pressed and then the start button is pressed and the pump will run at the programmed speed for each of the 4 buttons. To operate the pump in manual mode, press one of the 4 speed buttons and press the start /stop button to run the assigned speed for that button. When the pump is running a manual speed setting and a scheduled speed is set to run, the scheduled speed will take priority. When the scheduled speed time is over the pump will revert back to the manually pressed speed. If the pump is running a schedule and a speed button is pressed manually, the pump will run the manually selected speed until the next scheduled speed program.

**EGG TIMER (Duration)** – Speeds 1-4 can be programmed to run for duration of time once pressed. This means that the speed button is pressed, then the start button is pressed and the pump will run at a programmed speed and the speed will turn off at the end of a pre programmed amount of time.

**SCHEDULE:** The speed button can be programmed to turn on and off at a certain time. The LED above the start/ stop button must be illuminated for the pump to run schedules. When a speed is set to run in schedule mode it can still be operated manually. When a speed is programmed to run 23 hours and 59 minutes it will not turn off.  
Example: Pump start time 8:00 am pump stop time 7:59 am

**NOTE** When the pump is running a manual speed and password time out is activated the pump turned off but it cannot be turned back on. Pressing the Start / Stop button places the pump in the Running Schedule mode. It will only run speeds that are scheduled to come on at their scheduled start time.

## PUMP MENUS

**SET TIME:** Allows you to set the time in the pump system. This time is used to run scheduled start and stop programs. The pump will retain the set time for 96 hours after power to pump is turned off.

### To set time:

1. Check that the green power LED light is on
2. Press the Menu Button. “Settings” is displayed
3. Press the select button. Pump Address is displayed
4. Use the up or down arrow to scroll to “Set Time”
5. Press the select button. The cursor will appear in the minutes column
6. Press up or down arrow to set the time
7. Press Enter to save time setting
8. Press escape button to exit

### To set AM/ PM

1. Check that the green power LED light is on
2. Press Menu button. Settings is displayed
3. Press Select button. “pump address” is displayed
4. Use the up or down arrow to scroll to “AM/ PM”
5. Press the Select button
6. Press the up or down arrow to choose between 24hr AM/PM
7. Press enter to save the setting
8. Press Escape button to exit

### **Set Temperature Unit**

Use this to set the temperature to Celsius or Fahrenheit. The anti-freeze protection feature can be set to either unit of measure

1. Check that the green power LED is on
2. Press the Menu Button. "Settings" is displayed
3. Press Select button. "Pump Address" is displayed
4. Use the up or down arrow to scroll to "Temperature Units" menu item. The factory default setting is Fahrenheit
5. Press the select button. "F" is displayed
6. Press up or down arrow to choose between "F" Fahrenheit or "C" Celsius setting
7. Press enter to save your selection
8. Press Escape to Exit

### **Screen Contrast Level**

The contrast level of the screen can be adjusted for low or high lighting conditions

1. Check that the green power LED is on
2. Press the Menu Button. "Settings" is displayed
3. Press Select button. "Pump Address" is displayed
4. Use up or down arrow to scroll to "Contrast Level"
5. Press select button. Screen will show contrast setting number. The default is "15"
6. Press select button to change setting. Number will highlight
7. Press enter button to save selection
8. Press Escape button to exit

### **Setting Language**

1. Check that the green power LED is on
2. Press the Menu Button. "Settings" is displayed
3. Press Select button. "Pump Address" is displayed
4. Use up or down arrow to scroll to "Language"
5. Press select button to access menu
6. Press select to highlight current language
7. Press enter button to select the desired language
8. Press escape button to exit

### **SET MINIMUM SPEED**

The minimum speed can be set anywhere from 450 PRM to 1700 RPM. The default speed is 450 RPM.

1. Check that the green power LED is on
2. Press the Menu Button. "Settings" is displayed
3. Press Select button. "Pump Address" is displayed

4. Use up or down arrow to scroll to “Set Min. Speed”
5. Press Select button to change the setting. The cursor will appear in the first number column
6. Press up or down arrow to change the pumps minimum speed setting from 450 RPM to up to 1700 RPM
7. Press Enter button to save setting
8. Press Escape button to exit

### **SET MAXIMUM SPEED**

The maximum speed can be set anywhere from 1900 PRM to 3450 RPM. The default speed is 3450 RPM

1. Check that the green power LED is on
2. Press the Menu Button. “Settings” is displayed
3. Press Select button. “Pump Address” is displayed
4. Use up or down arrow to scroll to “Set Max. Speed”
5. Press Select button to change the setting. The cursor will appear in the first number column
6. Press up or down arrow to change the pumps maximum speed setting from 1900 RPM to up to 3450 RPM
7. Press Enter button to save setting
8. Press Escape button to exit

**CAUTION THE MAXIMUM FLOW RATE SETTING SHOULD BE SET SO THE SYSTEM NEVER OPERATES AT OR ABOVE 0.635 METER VACUUM.**

### **SETTING PASSWORD**

When the password feature is enabled, the pump will enter into password protection mode for a pre programmed amount of time after the last button is pressed. The entered password is any combination of four (4) digits.

1. Check that the green power LED is on
2. Press the Menu Button. “Settings” is displayed
3. Press Select button. “Pump Address” is displayed
4. Use up or down arrow to scroll to “Password”
5. Press the select button. The default setting is “Disabled”
6. Press the select button to change the setting
7. Press the up or down arrow to change the setting to “Enabled”
8. Press the enter button to save the setting

9. Press the down arrow button. "Password timeout" is displayed
10. Press select to change time from 1 minute to up to 6 hours
11. Press the enter button
12. Press down arrow button. Enter password is displayed
13. Press Select button to change setting
14. Press left or right arrow button to move cursor and move up and down arrow to change the password to desired setting
15. Press enter to save setting
16. Press escape to exit

## **PASSWORD PROTECTION**

The default setting is 1111 , which means the pump does have password protection straight from the factory. When this feature is enabled for a preset amount of time after the last button is pressed, the pump will prompt the user for a password before allowing access to the control panel and buttons. The password must be a 4 numeric digit password.

- When the pump is password protected it can always be turned off by pressing the Start/ Stop button
- When running in the manual mode it cannot be turned back on with the press of the Start / Stop button
- Pressing the start/stop button when the pump is off will return it back to the Running Cycles Mode and will run at the next scheduled run time. If the present time is within the scheduled run time the pump will run at the scheduled speed
- All functions including programming are disabled in Password protection mode
- If any buttons other than Start/ Stop are pressed, the screen reads enter password
- When Password Protection is enabled there is a Key icon on the screen

## **CHOOSING WORK MODE**

The pump has three operating modes: MANUAL / EGG TIMER / SCHEDULE

1. Press Menu button. "Settings" is displayed
2. Use the up or down arrow to scroll to" WORK MODE"
3. Press the select button. "Manual" is displayed
4. Use the up or down arrow to choose mode
5. Press Enter button to save the setting
6. Press escape button to exit

## **MANUAL WORK MODE**

1. Press the Menu button. 'Settings" is displayed
2. Us the up or down arrow to scroll to manual
3. Press the select button "Manual speed 1" is displayed
4. Use the up or down arrow to choose Manual speed 1, 2, 3 or 4
5. Press select button. Set speed to be displayed, then to change the speed
6. Press enter to save setting
7. Press escape to exit

## **EGG TIMER MODE**

1. Press the Menu Button. “Settings” is displayed
2. Use to up or down arrow to scroll to Egg timer
3. Press select. “Egg Speed” is displayed
4. Use the up or down arrow to choose ‘Egg Speed’ , “Egg Time”
5. Press select button and set either speed or time
6. Press enter button to save setting
7. Press escape to exit

## **SCHEDULE MODE**

1. Press the Menu button. ‘Settings” is displayed
2. Use the up or down arrow to scroll to schedule
3. Press the Select button. “Start Cycle 1” is displayed
4. Use the up or down arrow to choose what cycle to start or stop
5. Press the select button. Then set the start time. Stop time or speed
6. Press the Enter button to save the setting or cancel any changes press escape button to exit without saving
7. Press Escape to exit

## **QUICK CLEAN**

This feature can be used to ramp up the pump to a higher RPM for vacuuming, cleaning, adding chemicals or extra skimming . Press the quick clean button and then the Start/ Stop button to start the pump and reset the duration of time. When the quick Clean cycle is over it will resume regular schedules and will be in “Running Schedules” mode.

1. Check that the green power LED is on
2. Press the Menu button. “Settings” is displayed
3. Use the up or down arrow button to scroll to “FEATURES”
4. Press the select button. “Timeout” is displayed
5. Use down arrow. ‘Quick Clean” is displayed
6. Press the select button. “Set speed” is displayed
7. Press select button. The RPM column will highlight
8. Press up or down to change speed
9. Press enter to save speed setting
10. Press the down arrow. “Time Duration” is displayed
11. Press Select button. The cursor will appear in minutes column
12. Use up or Down arrow to change time
13. Press Enter to save setting
14. Press Escape to exit

## TIME OUT MODE

This feature keeps the pump from running for a programmable amount of time. This feature can be used to allow newly glued pipe joints time to dry. When this features time is up, the pump will be in the “running schedule” mode.

1. Check that the green power LED is on
2. Press the Menu button. “ Settings” is displayed
3. Use the down arrow to scroll to “Features”
4. Press the select button. “ Timeout” is displayed
5. Press the select button. The Minutes column will highlight
6. Press the left arrow to scroll to the hours setting. Time can be set from 1 minute to 10 hours
7. Press enter button to save setting
8. Press escape to exit

## **\*IMPORTANT NOTE\***

### **\*THE THERMAL MODE IS DISABLED ON THIS PUMP\***

The sensor for Thermal Mode is in the drive, on top of the motor. This feature allows you to set a speed (450 RPM — 3450 RPM) that runs when the Pump goes into Thermal Mode. The temperature level that you wish Thermal Mode to start can also be set

**NOTE** This Feature is for protection of the pump. Do not depend on the Thermal Mode feature for freeze protection of the pool. Certain situations could cause the pump to sense a different temperature than actual air temperature

Your automation systems air temperature sensor should be used to sense actual temperature. For example, if the pump is located indoors, the temperature of the room does not indicate the outdoor temperature. The pump does not sense the water temperature

## **TO ACCESS THE THERMAL MODE MENU:**

1. Check that the green power **LED** is on
2. Press **Menu**
3. Use the **Down** arrow to scroll to “Thermal Mode” and press **Enter**
4. The factory default for Thermal Mode is “Disabled”. To Enable Thermal mode, press **Enter** to highlight “Enabled”
5. Press the **Down** arrow — “Enabled” is displayed
6. Press **Enter** to save



## TO SET THERMAL SPEED AND PUMP TEMPERATURE

**NOTE** Thermal Mode features are only accessible if Thermal Mode is Enabled

1. With Thermal Mode displayed on the screen, press the **Down** arrow — Set Speed is displayed. The factory default is 1000 RPM
2. Press **Enter** to change the speed. The cursor will highlight the first column (ones)
3. Use the **Up** or **Down** arrows to set speed (450 — 3450 RPM)
4. Press **Enter** to save the speed
5. Press the **Down** arrow to Pump Temperature (the temperature of the pump will activate Thermal Mode, default is 40° (4.4° C)
6. Press **Enter** to change the setting. The cursor will highlight the first column. Can be set 40° F to 50° F (4.4° C — 10° C)
7. Press **Enter** to save the temperature setting  
**NOTE:** To cancel any changes, press **Back** to exit without saving
8. Press **Back** to exit

### ALERTS AND WARNINGS

The pump displays all alerts and warnings on the control panel. When an alarm or warning condition exists, the corresponding LED will be lit on the display. All control panel buttons are disabled until the alarm or warning is acknowledged with the ENTER button. Press the RESET button to clear the alarm once the fault condition has been resolved.

**POWER OUT FAILURE** – Incoming supply voltage is less than 170 VAC.

**PRIMING ERROR** – If the pump is not defined as primed within the maximum priming time it will stop and generate a priming alarm for 10 minutes, then attempt to prime again. If the pump cannot prime within 5 attempts it will generate a permanent alarm and have to be manually reset.

**OVERHEAT ALERT** – If the drive temperature gets over 103 Degrees Fahrenheit the pump will slowly reduce speed until the temperature condition clears.

**ANTI FREEZE** – When active, the motor will run at the preset RPM until the drive temperature increases above the minimum.

**OVER CURRENT** – Indicates that the drive is overloaded or the motor has an electrical problem. The drive will restart 20 seconds after the over current condition clears.

**OVER VOLTAGE** – Indicates excessive supply voltage or an external water source is causing the pump and motor to rotate thereby generating excessive voltage in the drive's internal DC buss. The drive will restart 20 seconds after the over voltage condition clears.

# TROUBLE SHOOTING GUIDE

<b>PROBLEM</b>	<b>POSSIBLE CAUSE</b>	<b>SOLUTION</b>
<b>Pump failure</b>	<p>Pump will not prime - Air leak in suction. PRIME ERROR may be displayed</p> <p>Pump will not prime - Not enough water</p> <p>Pump does not come out of prime</p> <p>Pump stainer gasket is clogged</p> <p>Pump strainer gasket is defective</p> <p>Air pockets or leaks in suction line. PRIME ERROR may be displayed</p>	<p>Check suction piping and valve glands on any suction gate valves. Secure lid on pump strainer pot and be sure lid gasket is in place. Check water level to be sure skimmer is not drawing air. Be sure the suction lines, pump.</p> <p>Strainer, and pump volute are full of water.</p> <p>Adjust prime sensitivity to a higher setting (default setting is 1%).</p> <p>Clean pump strainer pot.</p> <p>Replace gasket.</p> <p>Check suction piping and valve glands on any suction gate valves. Turn off electrical power to the pump.</p>
<b>Reduced capacity and/or head.</b>	<p>Clogged impeller. PRIME ERROR may be displayed</p>	<p>Remove the (6) bolts that holds the housing (strainer pot/volute) to seal plate. Slide the motor and seal plate away from the volute.</p> <p>Clean debris from impeller. If debris cannot be removed, complete the following steps:</p> <ol style="list-style-type: none"> <li>1. Remove diffuser and o-ring.</li> <li>2. Remove left hand thread anti-spin bolt and o-ring.</li> <li>3. Remove, clean and reinstall impeller.</li> <li>4. Reinstall anti-spin bolt and o-ring.</li> </ol> <p>Reinstall diffuser, and o-ring.</p> <p>Reinstall motor and seal plate into volute.</p> <p>Reinstall clamp band around seal plate and volute and tighten securely.</p>

<b>PROBLEM</b>	<b>POSSIBLE CAUSE</b>	<b>SOLUTION</b>
<b>Pump trips and restarts constantly.</b>	Pump strainer pot clogged. PRIME ERROR may be displayed	Clean suction trap.
	Air in system	Bleed air from filter. Ensure that air bubbles are not visible coming into pump pot.
	Suction lift above design limits	Insert vacuum gauge into pump port connection port. Confirm vacuum level is 25 in. mercury (hg) or less. Stop pump and clear blockage.
	Blocked suction Blocked discharge	
	System flow too high. System changing flow too quickly. In floor cleaning system issues	Reduce system flow. Change speed. Reduce water flow. In floor cleaning systems must be designed with balanced hydraulic losses on all legs.
	Priming not enabled	Enable priming from the "PRIMING" menu.
Issues related to other equipment, such as Heat Pumps and Heaters with internal valves that vibrate	Lowering speed below 200 RPM may resolve the issue or addition of external manual valve controls, may resolve issue.	
<b>Inadequate circulation</b>	Filter or pump basket dirty	Check trap basket; if plugged, turn pump off and clean basket.
	Suction/discharge piping is too small.	Check and clean pool filter. Increase piping size.
	Speed is set too slow for proper filtration cycle	Increase filtration run time

<b>PROBLEM</b>	<b>POSSIBLE CAUSE</b>	<b>SOLUTION</b>
<b>Electrial Problem</b>	Could appear as a “Low Voltage” alarm. PRIME ERROR may be displayed	Check voltage at motor terminals and at panel while pump is running. If low, see wiring instructions or consult power company. Check for loose connections.
	Could appear as “Over Heat” alert. PRIME ERROR may be displayed	Check line voltage; if less than 90% or more than 110% of rated voltage consult a licensed electrician. Increase ventilation. Reduce ambient temperature. Tighten any loose wiring connections. Motor internal terminal overload protector is open. Motor runs too hot. Turn power to motor off. Check for proper voltage. Check for proper impeller or impeller rubbing.
<b>Mechanical Troubles and Noise.</b>	The pump motor is running but with loud noise	If suction and discharge piping are not adequately supported, pump assembly will be strained. Do not mount pump on a wooden platform! Securely mount on concrete platform for quietest performance.
	Foreign matter (gravel, metal, etc.) in pump	Disassemble pump, clean impeller, follow
	Impeller  Cavitation	Pump service instructions for reassembly.  Improve suction conditions. Increase pipe size. Decrease number of fittings. Increase discharge pressure.



**Blue Torrent** manufactures all of its products using cutting-edge technology with the best materials and workmanship available.

**Blue Torrent's PUMPS AND FILTERS** are warranted as follows:

## **1 YEAR LIMITED WARRANTY**

**Blue Torrent** warrants its Pumps and Filters to be free of defects in material and/or workmanship for a period of one year from the original date of purchase and/or installation.

### **WARRANTY CLAIM EXCLUSIONS:**

- Damage caused by improper installation as specified in owner's manual
- Damage caused by improper handling
- Damage due to misuse, abuse and/or failure to operate item per owner's manual
- Damage caused by improper water chemistry
- Damage caused by improper winterization of equipment
- Damage caused by not using original **Blue Torrent** replacement parts
- Damage caused by improper wiring or use of extension cords
- Accidental damage, fire, acts of God or other circumstances outside of **Blue Torrent's** control

#### **NOTE:**

- Customer must retain the original sales invoice as proof of purchase along with the installers invoice (to establish date of installation)
- Commercial facilities are not covered by warranty

Please return any and all defective items to your local authorized **Blue Torrent** dealer for inspection.

**The customer is responsible for all shipping charges to and from the nearest Factory Warranty Center. For more information. Please visit [www.btwarranty.com](http://www.btwarranty.com)**

Should a defect in material or workmanship appear the product will be repaired or replaced at our discretion. **Neither Blue Torrent nor any authorized dealer is responsible for any charges related to the installation of the new item or part.** Nor are they responsible for any incidental charges incurred including, but not limited to, water, chemicals, landscaping or any other associated expenses.