

COPPERFORCE PUMP INSTRUCTIONS

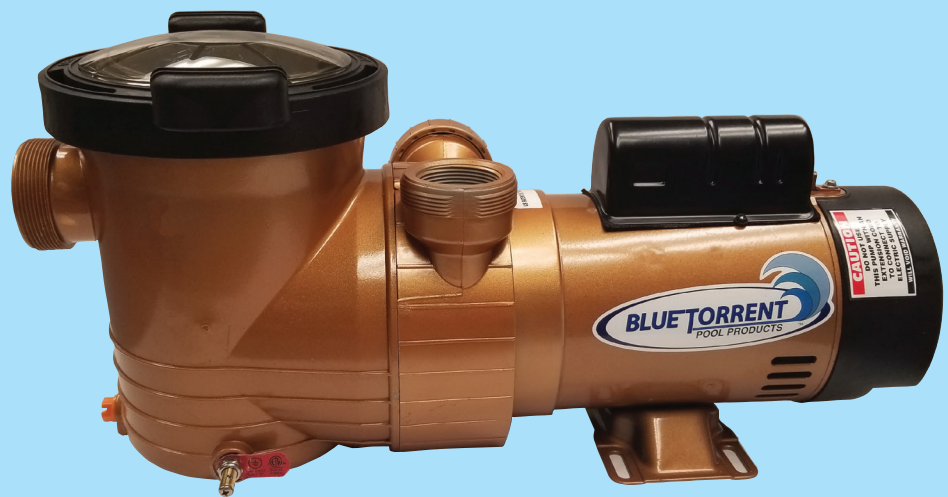

**READ THIS MANUAL CAREFULLY BEFORE
USING YOUR NEW PUMP**

COPPERFORCE PARTS BREAKDOWN

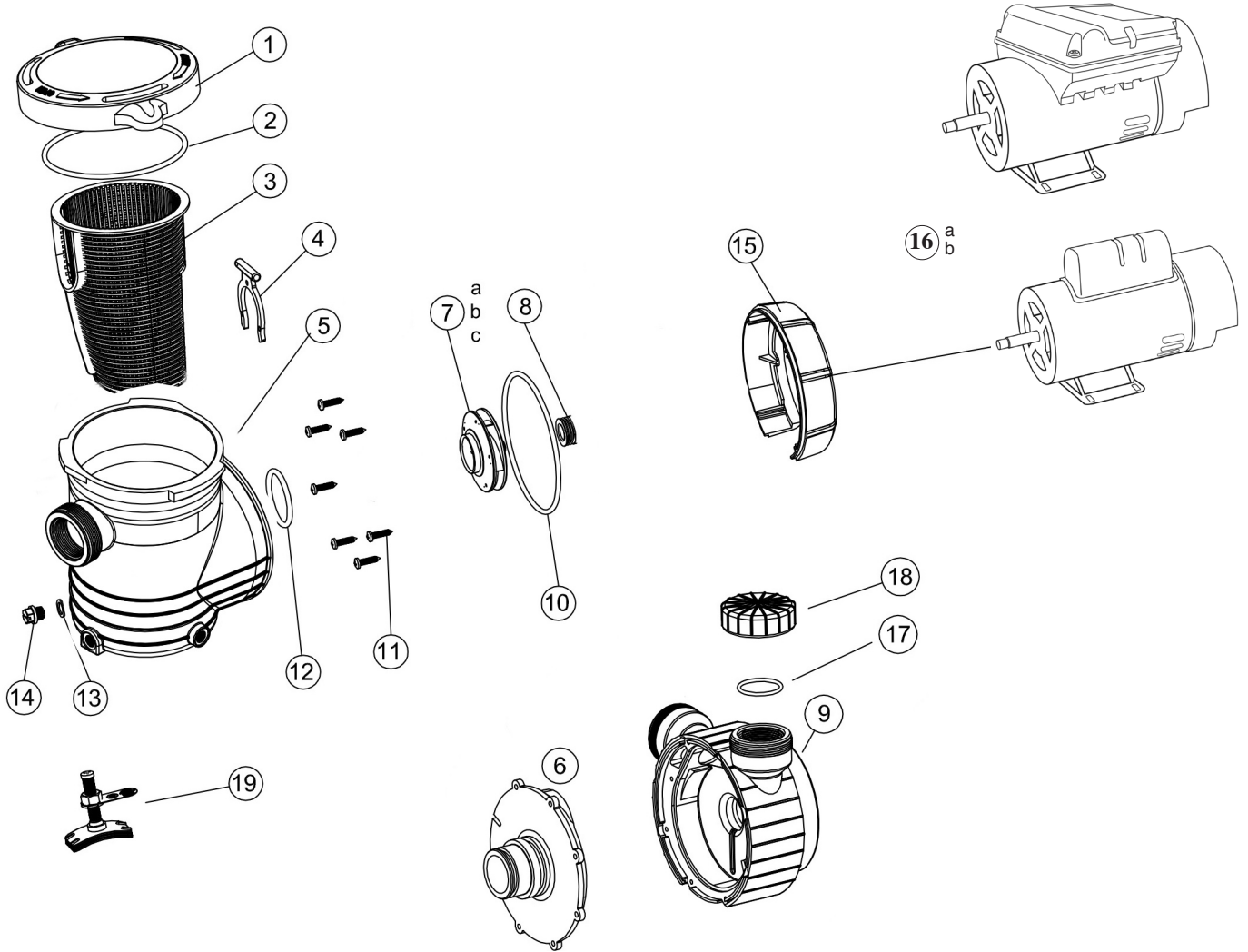

PART #	MODEL #	DESCRIPTION	COPPERFORCE
1	AC 81361	Pump Lid	1
2	AC 81396	Pump Lid O-Ring	1
3	AC 81434	Pump Basket	1
4	AC 81744	Strainer Clip	1
5	AC 23604	Strainer Housing	1
6	AC 31569	Dual Port Cover	1
7A	AC 81795	Impeller 1 HP	1
7B	AC 81817	Impeller 1.5 HP	1
7C	AC 81868	Impeller 2 HP	1
8	AC 81876	Seal Set	1
9	AC 31569	Dual Port Pump Housing	1
10	AC 81892	Pump Housing O-Ring	1
11	AC 81914	Pump Screws	7
12	AC 81922	Pump Cover O-Ring	1
13	AC 81590	Drain Plug O-Ring	1
14	AC 81620	Drain Plug	1
15	AC 83429	Motor Flange	1
17-18	AC 31577	Dual Port Cap/O-Ring	1
19	AC 51895	Bonding Plate	1

IMPORTANT SAFETY INSTRUCTIONS

NOTE All wiring should be done by a qualified electrician in accordance to the National Electric Code and all Local Codes and ordinances.

When installing and using this electrical equipment, basic safety precautions should ALWAYS be followed.

READ AND FOLLOW ALL INSTRUCTIONS



WARNING

1. To reduce the risk of injury, do not allow children to use this equipment
2. Connect only to a grounding type receptacle that is protected by a ground fault circuit interrupter (GFCI).
3. Do not bury the cord. Locate cord so it would not come in contact with lawn mowers, trimmers or other equipment.
4. Do not connect this equipment to an extension cord. To reduce the risk of electric shock, only connect the electric cord to a properly located outlet.
5. To reduce the risk of shock, replace damaged cords immediately. Do not use this equipment if cord appears damaged.
6. To reduce the risk of shock, connect ground wires to the grounding screw located in the motor.
7. To reduce the risk of shock, a bonding connector is provided for bonding to any metal within 5 feet of the swimming pool. All local points should be bonded with #8AWG (8.4mm²) wire.

NOTE To installer and/or operator of the Copperforce swimming pool pump: the manufacturer's warranty will be void if the pump is improperly installed and/or operated.

OPERATION AND MAINTENANCE

PUMP LOCATION

1. Locate the pump on a level surface as close to the pool as practical. Consult local codes for minimum distances between pool and pump if applicable.
2. The connection plumbing (hose or rigid pipe) should be direct and as free from turns and bends as possible. Take care not to kink flexible hose. Elbows and other fittings greatly increase friction losses.
3. Place pump on a solid foundation / base which provides a rigid and vibration free support.
4. Protect the pump against flooding and excess moisture. Protect the motor from foreign objects clogging the air circulation around the motor.
5. **NEVER** use gasoline or other flammable liquids or vapors in the vicinity of this pump.

NOTE DO NOT store pool chemicals near this pump.
DO NOT remove any safety labels such as CAUTION / DANGER / WARNING from this pump. Keep labels in good condition and replace any damaged labels.



WARNING

Keep labels in good condition and replace any damaged labels

PUMP INSTALLATION

1. When connecting plumbing fittings to the pumps threaded ports, it is recommended that thread seal tape (Teflon tape) be used. If the suction (intake) connection is not sealed correctly the pump will not prime properly and will pump only small volumes of water or no water at all.
2. When installing the pump the suction line (hose or pipe) must be below the swimming pool water level to a point immediately beneath the pump to ensure priming via a flooded suction line. The height between the water line and pump should never be more than 5 feet.
3. Suction and discharge lines should be independently supported at a point near the pump to avoid strains being placed on the pump.
4. It is advisable to install a gate valve or union in both the suction and discharge lines in the event the pump needs servicing or removal.
5. Before starting the pump for the first time remove the clear lid at the front of the pump. Turn the lid counterclockwise to remove. Fill the pump strainer with water until it is level with the suction port opening. Replace the lid making sure the lid is tight and O-Ring is not damaged. Hand tighten only.
6. **BONDING:** as required by the National Electrical Code Article 680-26 the pump must be electrically bonded to the pool structure by a solid copper conductor no smaller than #8 AWG via the external copper bonding lug on the motor.
7. **GROUNDING:** Permanently ground the pump motor using a conductor of appropriate size. Connect to the green headed screw provided inside the motor terminal box.

NOTE DO NOT CONNECT MOTOR TO THE ELECTRIC POWER SUPPLY UNTIL IT IS PERMANENTLY GROUNDED.

PRIMING THE PUMP

1. Make sure the hair and lint trap is full of water. It may be necessary to open hair and lint lid and allow trap a fill with water.

IF PUMP IS EQUIPPED WITH BUILT IN TIMER



Timer control allows you to set the Coppeforce pump to run at up to 2 different time intervals up to 10 hours each.

The AM RUN will begin at the AM time you have selected and run for the duration you selected 2, 4, 6, 8 or 10 hours before turning off.

The PM RUN will begin at the PM time you have selected (if any) and run for the duration you selected 2, 4, 6, 8 or 10 hours before turning off.

TO SET CURRENT TIME

- Press current time button
- Press up and down arrows to change the hour Note: The clock is on 24 hour time so 1 PM is 13:00
- Use the left and right arrows to change the minutes
- When time is correct press enter

TO SET AM RUN

- Select AM — AM light will appear press enter
- Using the up and down arrows to change the hour
- Use the left and right arrows to change the minutes
- Press Enter to set
- To set AM run length press Run 1 until desired LED is lit. You can choose 2-4-6-8-10 hours or off

TO SET PM RUN

- Select PM — PM light will appear press enter
- Using the up and down arrows to change the hour
- Use the left and right arrows to change the minutes
- Press Enter to set
- To set PM run length press Run 1 until desired LED is lit. You can choose 2-4-6-8-10 hours or off

CONTINUOUS RUN MODE

- To run pump continuously and bypass timer:
- Press continuous run so LED is illuminated
- Press ON/OFF to turn pump ON/OFF

COPPERFORCE DUAL PORT DISCHARGE

- You can use the horizontal or the vertical port to connect to your filter. Once you select which port you are using you need to install the discharge cap onto the other port opening. Simply screw the cap into position on the unused port. Hand tighten only and continue to connect your pump to the filter tank with connections provided with the filter.

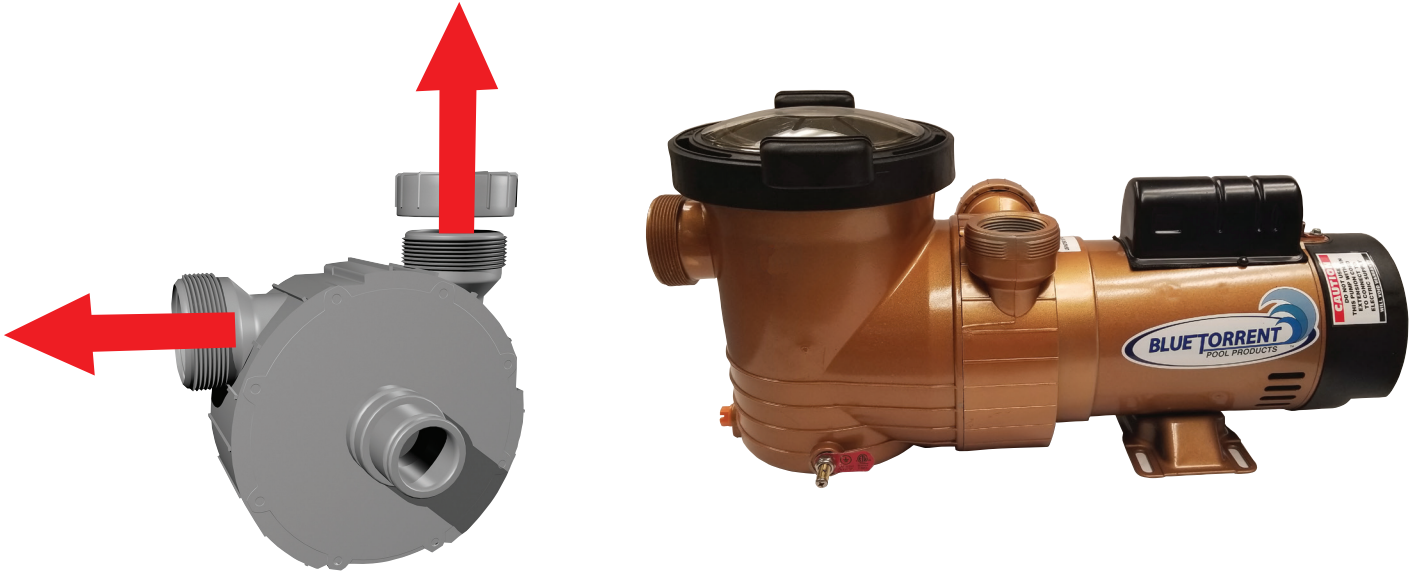

PUMPS EQUIPPED WITH PRE BONDED HLT DISCHARGE

- The bonding post is installed in the bonding port of the pump housing (pic A)
- Disassemble bonding post. Remove bonding screw, nut, plate and washer from the bonding post (pic B)
- Insert the bonding post into the bonding port from the inside of the pump housing (pic C)
- Reinstall the washer, plate nut and screw in that order onto the bonding post (pic D)
 - Tighten the nut firmly onto the bonding post
 - To ground the water in the pool using the Bonding plate you **MUST** use an independent copper ground wire. **DO NOT USE THE SAME GROUND CONNECTED TO THE ELECTRIC MOTOR.**

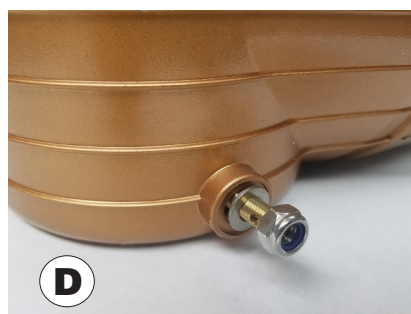
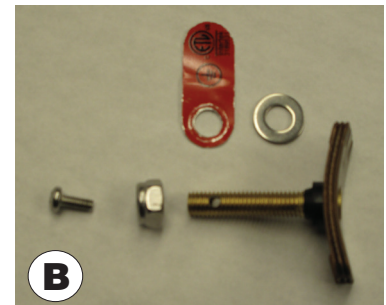

PUMP MAINTENANCE

- The pump requires little to no maintenance other than reasonable care and cleaning of the strainer basket on a regular basis. The pump is equipped with a mechanical seal. This seal may eventually come loose of a period of time, depending on running time and water quality. If water continually leaks out, a new mechanical seal should be installed.
- See parts diagram for seal location.
- The pump is equipped with a rubber O-Ring that seals the strainer basket lid. This O-Ring should be lubricated with water proof lubricant (O-RING LUBE) to ensure proper seal and extend O-Ring life. If O-Ring becomes cracked or worn (flattened) is will become necessary to replace.

COPPERFORCE PUMPS EQUIPPED WITH ON/OFF SWITCH

- If your Copperforce pump is equipped with an ON/OFF switch you can power the pump on and turn it off without having to unplug the pump
- The ON/OFF switch is located at the rear of the motor
- Press the left side of the switch to turn the pump ON
- Press the right side of the switch to turn the pump OFF

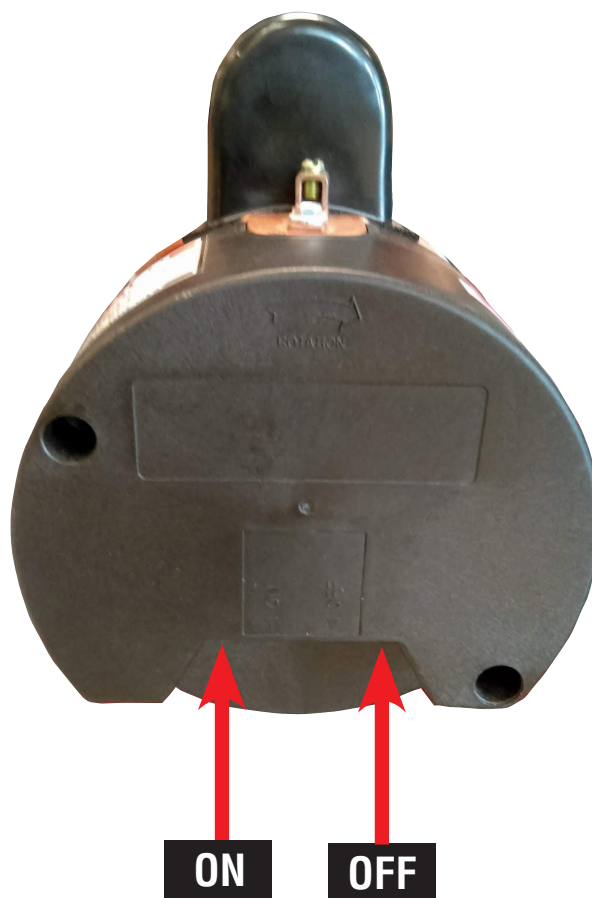

WINTERIZATION

- In areas subject to freezing temperatures, it is recommended that the pump be disconnected and stored indoors in a warm and dry location. Remove the drain plugs from the pump housing and place them in the strainer basket for storage.

DO NOT BLOCK SUCTION

1. Pump suction is dangerous and can trap and drown or disembowel bathers.
2. Blocking suction with body may cause severe and/or fatal injury
3. Do not operate swimming pools, spas or hot tubs if a suction outlet cover is missing, broken or loose
4. Suction outlet must be replaced if cracked, broken or missing.
5. All suction outlets must have correctly installed screw fastened covers in place.



WARNING

RISK OF ELECTRICAL SHOCK

1. To avoid dangerous or fatal electrical shock, **TURN OFF** power to motor **BEFORE** working on electrical connections.
2. To reduce the risk of electrical shock, unplug motor before working on pump or motor.

TROUBLE SHOOTING GUIDE

PROBLEM	POSSIBLE CAUSE	SOLUTION
Pump will not Prime	Suction Air Leak	<p>Make sure see thru lid and O-Ring are clean, lubricated and tightened. Tighten all hoses and pipes on the suction side of the pump.</p> <p>Be sure water level in the swimming pool is high enough to flow through skimmer. Be sure skimmer port is not plugged or blocked</p>
	No Water in Pump	<p>Make sure strainer tank is full of water</p>
	Closed Valves or Blocked Lines	<p>Open all valves in system. Clean skimmer and strainer basket. Check for blockage in impeller</p>
	Low Voltage to Motor	<p>Check voltage at motor. If low, pump will not come up to speed</p>
Motor Does Not Run	No Power to Motor	<p>Check that all power switches are on. Be sure fuse or circuit breaker is properly set. Check motor wiring at terminals</p>
	Pump Jammed	<p>With power off, turn motor shaft. It should spin freely. If not disassemble and repair</p>
Low Flow	Dirty Filter	<p>Backwash filter. When pressure is high you must backwash or clean filter</p> <p>Clean skimmer basket. Clean pump basket</p>
	Suction Air Leak	<p>See above</p>
	Closed Valve	<p>See above</p>
Motor Runs Hot	<p>Motor is designed to run hot to the touch, this is normal. They are equipped with a thermal overload protector which will turn the motor off if there is an overload or high temperature problem. Excessive heat can be caused by:</p>	
	Poor Ventilation	<p>Do not enclose motor, be sure to have a proper air space around motor</p>
	Installed in direct sun	<p>Shield motor from sun's rays</p>