

VARIABLE SPEED PUMP

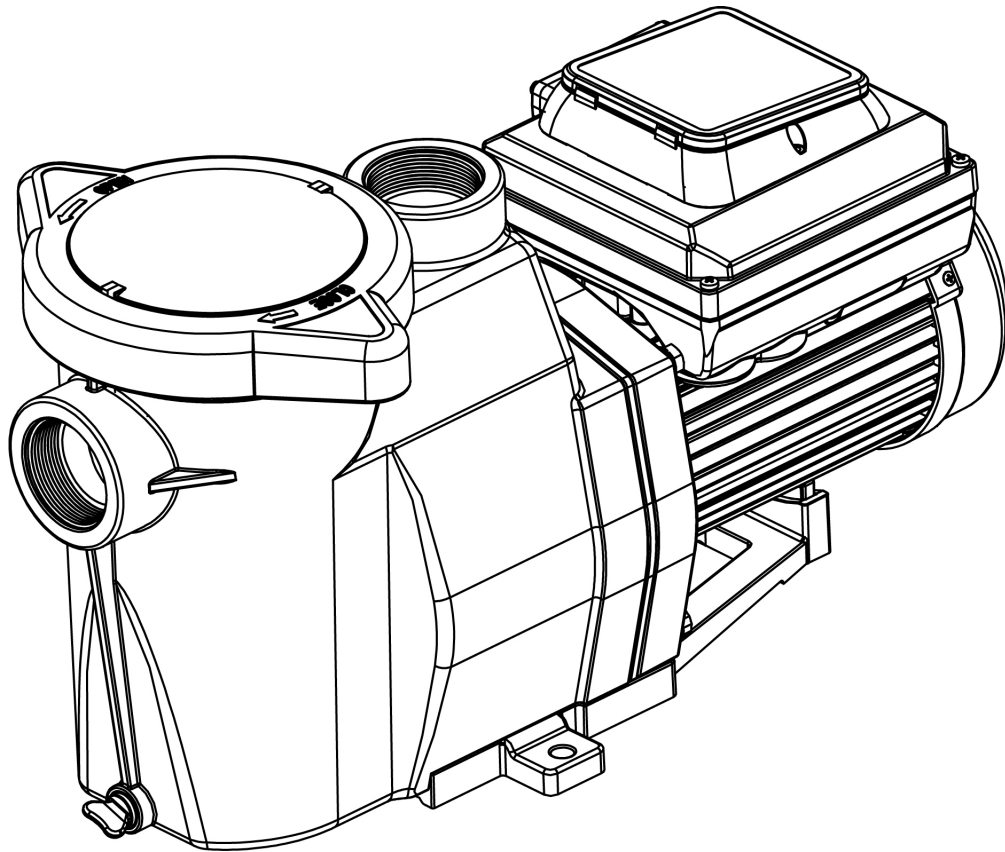

INSTALLATION AND USER'S GUIDE

IMPORTANT SAFETY INSTRUCTIONS
READ AND FOLLOW ALL INSTRUCTIONS
SAVE THESE INSTRUCTIONS

TABLE OF CONTENTS

Important Pump Warning and Safety Instructions	ii	Maintenance	8
Pump Overview	1	Pump Strainer Basket	8
Pump Overview	1	Cleaning the Pump Strainer Basket	8
General Features	1	Winterizing	8
Controller Features	1	Servicing	9
Controller Overview	1	Electric Motor Care	9
Control Panel Overview	2	Shaft Seal Replacement	9
Keypad Navigation	2	Pump Disassembly	9
Installation	3	Pump Reassembly	10
Location	3	Restart Instructions	10
Piping	3	Troubleshooting	11
Fitting and Valves	3	Errors and Alarms	12
Electrical Requirements	3	Replacement Parts	13
Wiring Overview and Installation	4	Illustrated Parts List	13
Operating the Pump	5	Pump Performance Curves	14
Setting the Clock	5	Model Specifications	14
Using the Default Schedule	5	Pump Dimensions	15
Speed 1 and Priming	5		
Custom Schedules	6		
Speed Priorities and Quick Clean	7		
Operating the Pump While Running	7		

IMPORTANT PUMP WARNING AND SAFETY INSTRUCTIONS



IMPORTANT NOTICE

This guide provides installation and operation instructions for this pump. Consult Pentair with any questions regarding this equipment.

Attention Installer: This guide contains important information about the installation, operation and safe use of this product. This information should be given to the owner and/or operator of this equipment after installation or left on or near the pump.

Attention User: This manual contains important information that will help you in operating and maintaining this product. Please retain it for future reference.

READ AND FOLLOW ALL INSTRUCTIONS SAVE THESE INSTRUCTIONS



This is the safety alert symbol. When you see this symbol on your system or in this manual, look for one of the following signal words and be alert to the potential for personal injury.

⚠ DANGER

Warns about hazards that can cause death, serious personal injury, or major property damage if ignored.

⚠ WARNING

Warns about hazards that may cause death, serious personal injury, or major property damage if ignored.

⚠ CAUTION

Warns about hazards that may or can cause minor personal injury or property damage if ignored.

NOTE

Indicates special instructions not related to hazards.

Carefully read and follow all safety instructions in this manual and on equipment. Keep safety labels in good condition; replace if missing or damaged.

When installing and using this electrical equipment, basic safety precautions should always be followed, include the following:

⚠ WARNING Do not permit children to use this product.

⚠ WARNING **RISK OF ELECTRICAL SHOCK.** Connect only to a branch circuit protected by a ground-fault circuit-interrupter (GFCI). Contact a qualified electrician if you cannot verify that the circuit is protected by a GFCI.

⚠ WARNING This unit must be connected only to a supply circuit that is protected by a ground-fault circuit-interrupter (GFCI). Such a GFCI should be provided by the installer and should be tested on a routine basis. To test the GFCI, push the test button. The GFCI should interrupt power. Push the reset button. Power should be restored. If the GFCI fails to operate in this manner, the GFCI is defective. If the GFCI interrupts power to the pump without the test button being pushed, a ground current is flowing, indicating the possibility of an electric shock. Do not use this pump. Disconnect the pump and have the problem corrected by a qualified service representative before using.

⚠ CAUTION This pump is for use with permanent swimming pools and may also be used with hot tubs and spas if so marked. Do not use with storable pools. A permanently-installed pool is constructed in or on the ground or in a building such that it cannot be readily disassembled for storage. A storable pool is constructed so that it is capable of being readily disassembled for storage and reassembled to its original integrity.

General Warnings

- Never open the inside of the drive motor enclosure. There is a capacitor bank that holds a 230 VAC charge even when there is no power to the unit.
- The pump is not submersible.
- The pump is capable of high flow rates; use caution when installing and programming to limit pumps performance potential with old or questionable equipment.
- Code requirements for electrical connection differ from country to country, state to state, as well as local municipalities. Install equipment in accordance with the National Electrical Code and all applicable local codes and ordinances.
- Before servicing the pump; switch OFF power to the pump by disconnecting the main circuit to the pump.
- This appliance is not intended for use by persons (including children) of reduced physical, sensory or mental capabilities, or lack of experience and knowledge, unless they have been given supervision or instruction concerning the use of the appliance by a person responsible for their safety.

⚠ DANGER FAILURE TO FOLLOW ALL INSTRUCTIONS AND WARNINGS CAN RESULT IN SERIOUS BODILY INJURY OR DEATH. **THIS PUMP SHOULD BE INSTALLED AND SERVICED ONLY BY A QUALIFIED POOL SERVICE PROFESSIONAL. INSTALLERS, POOL OPERATORS AND OWNERS MUST READ THESE WARNINGS AND ALL INSTRUCTIONS IN THE OWNER'S MANUAL BEFORE USING THIS PUMP. THESE WARNINGS AND THE OWNER'S MANUAL MUST BE LEFT WITH THE POOL OWNER.**

⚠ DANGER SUCTION ENTRAPMENT HAZARD: STAY OFF THE MAIN DRAIN AND AWAY FROM ALL SUCTION OUTLETS!



THIS PUMP PRODUCES HIGH LEVELS OF SUCTION AND CREATES A STRONG VACUUM AT THE MAIN DRAIN AT THE BOTTOM OF THE BODY OF WATER. THIS SUCTION IS SO STRONG THAT IT CAN TRAP ADULTS OR CHILDREN UNDER WATER IF THEY COME IN CLOSE PROXIMITY TO A DRAIN OR A LOOSE OR BROKEN DRAIN COVER OR GRATE.

THE USE OF UNAPPROVED COVERS OR ALLOWING USE OF THE POOL OR SPA WHEN COVERS ARE MISSING, CRACKED OR BROKEN CAN RESULT IN BODY OR LIMB ENTRAPMENT, HAIR ENTANGLEMENT, BODY ENTRAPMENT, EVISCERATION AND/OR DEATH.

The suction at a drain or outlet can cause:

Limb Entrapment: When a limb is sucked or inserted into an opening resulting in a mechanical bind or swelling. This hazard is present when a drain cover is missing, broken, loose, cracked or not properly secured.

Hair Entanglement: When the hair tangles or knots in the drain cover, trapping the swimmer underwater. This hazard is present when the flow rating of the cover is too small for the pump or pumps.

Body Entrapment: When a portion of the body is held against the drain cover trapping the swimmer underwater. This hazard is present when the drain cover is missing, broken or the cover flow rating is not high enough for the pump or pumps.

Evisceration/Disembowelment: When a person sits on an open pool (particularly a child wading pool) or spa outlet and suction is applied directly to the intestines, causing severe intestinal damage. This hazard is present when the drain cover is missing, loose, cracked, or not properly secured.

IMPORTANT PUMP WARNING AND SAFETY INSTRUCTIONS

Mechanical Entrapment: When jewelry, swimsuit, hair decorations, finger, toe or knuckle is caught in an opening of an outlet or drain cover. This hazard is present when the drain cover is missing, broken, loose, cracked, or not properly secured.

NOTE: ALL SUCTION PLUMBING MUST BE INSTALLED IN ACCORDANCE WITH THE LATEST NATIONAL AND LOCAL CODES, STANDARDS AND GUIDELINES.

WARNING TO MINIMIZE THE RISK OF INJURY DUE TO SUCTION ENTRAPMENT HAZARD:

- A properly installed and secured ANSI/ASME A112.19.8 approved anti-entrapment suction cover must be used for each drain.
- Each suction cover must be installed at least three (3') feet apart, as measured from the nearest point to nearest point.
- Regularly inspect all covers for cracks, damage and advanced weathering.
- If a cover becomes loose, cracked, damaged, broken or is missing, replace with an appropriate certified cover.
- Replace drain covers as necessary. Drain covers deteriorate over time due to exposure to sunlight and weather.
- Avoid getting hair, limbs or body in close proximity to any suction cover, pool drain or outlet.
- Disable suction outlets or reconfigure into return inlets.

WARNING A clearly labeled emergency shut-off switch for the pump must be in an easily accessible, obvious place. Make sure users know where it is and how to use it in case of emergency.

The Virginia Graeme Baker (VGB) Pool and Spa Safety Act creates new requirements for owners and operators of commercial swimming pools and spas.

Commercial pools or spas constructed on or after December 19, 2008, shall utilize:

(A) A multiple main drain system without isolation capability with suction outlet covers that meet ASME/ANSI A112.19.8a Suction Fittings for Use in Swimming Pools, Wading Pools, Spas, and Hot Tubs and either:

- (i) A safety vacuum release system (SVRS) meeting ASME/ANSI A112.19.17 Manufactured Safety Vacuum Release systems (SVRS) for Residential and Commercial Swimming Pool, Spa, Hot Tub, and Wading Pool Suction Systems and/or ASTM F2387 Standard Specification for Manufactured Safety Vacuum Release Systems (SVRS) for Swimming pools, Spas and Hot Tubs or
- (ii) A properly designed and tested suction-limiting vent system or
- (iii) An automatic pump shut-off system.

Commercial pools and spas constructed prior to December 19, 2008, with a single submerged suction outlet shall use a suction outlet cover that meets ASME/ANSI A112.19.8a and either:

- (A) A SVRS meeting ASME/ANSI A112.19.17 and/or ASTM F2387, or
- (B) A properly designed and tested suction-limiting vent system, or
- (C) An automatic pump shut-off system, or
- (D) Disabled submerged outlets, or
- (E) Suction outlets shall be reconfigured into return inlets.

For Installation of Electrical Controls at Equipment Pad (ON/OFF Switches, Timers and Automation Load Center)

CAUTION Install all electrical controls at equipment pad, such as on/off switches, timers, and control systems, etc. to allow the operation (startup, shut-down, or servicing) of any pump or filter so the user does not place any portion of his/her body over or near the pump strainer lid, filter lid or valve closures. This installation should allow the user enough space to stand clear of the filter and pump during system start-up, shut down or servicing of the system filter.



DANGER

HAZARDOUS PRESSURE: STAND CLEAR OF PUMP AND FILTER DURING START UP



Circulation systems operate under high pressure. When any part of the circulating system (i.e. locking ring, pump, filter, valves, etc.) is serviced, air can enter the system and become pressurized.

Pressurized air can cause the pump housing cover, filter lid, and valves to violently separate which can result in severe personal injury or death. Filter tank lid and strainer cover must be properly secured to prevent violent separation. Stand clear of all circulation system equipment when turning on or starting up pump.

Before servicing equipment, make note of the filter pressure. Be sure that all controls are set to ensure the system cannot inadvertently start during service. Turn off all power to the pump. **IMPORTANT: Place filter manual air relief valve in the open position and wait for all pressure in the system to be relieved.**

Before starting the system, fully open the manual air relief valve and place all system valves in the "open" position to allow water to flow freely from the tank and back to the tank. Stand clear of all equipment and start the pump.

IMPORTANT: Do not close filter manual air relief valve until all pressure has been discharged from the valve and a steady stream of water appears. Observe filter pressure gauge and be sure it is not higher than the pre-service condition.

General Installation Information

- All work must be performed by a qualified service professional, and must conform to all national, state, and local codes.
- Install to provide drainage of compartment for electrical components.
- These instructions contain information for a variety of pump models and therefore some instructions may not apply to a specific model. All models are intended for use in swimming pool applications. The pump will function correctly only if it is properly sized to the specific application and properly installed.

WARNING Pumps improperly sized or installed or used in applications other than for which the pump was intended can result in severe personal injury or death. These risks may include but not be limited to electric shock, fire, flooding, suction entrapment or severe injury or property damage caused by a structural failure of the pump or other system component.

WARNING The pump can produce high levels of suction within the suction side of the plumbing system. These high levels of suction can pose a risk if a person comes within the close proximity of the suction openings. A person can be seriously injured by this high level of vacuum or may become trapped and drown. It is absolutely critical that the suction plumbing be installed in accordance with the latest national and local codes for swimming pools.

SAVE THESE INSTRUCTIONS

PUMP OVERVIEW

Pump Overview

The perfect choice for all types of pools, the Variable Speed Pump was specifically designed to be your best choice for a variety of in-ground pools.

Thick walled body parts, a heavy duty TEFC motor, and highly engineered hydraulics make this rugged and tested design perfect for any pool, spa, water feature, or fountain.

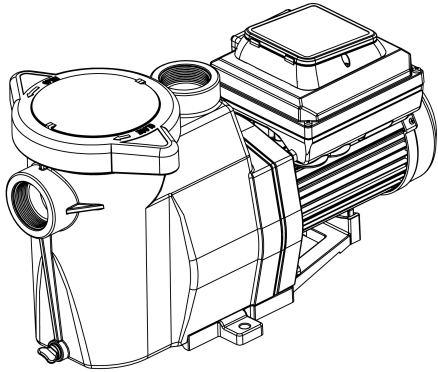

VARIABLE SPEED PUMP

General Features

- Extremely quiet operation
- Unionized fittings (1.5" and 2") for simple replacement
- Strainer cover kit for easy cleaning and maintenance
- Super-duty totally enclosed fan cooled (TEFC) motor for long life
- Integral volute and pot reduce hydraulic noise
- See-through lid permits easy inspection of strainer basket
- Self-priming for quick, easy start-up
- ETLUS/CETL Listed

Controller Features

- Simple user interface
- IPX6 certified UV and rain-proof enclosure
- Onboard time of day schedule
- Adjustable priming mode
- Programmable quick clean mode
- Diagnostic alarm display and retention
- Active power factor correction

- Accepts 230V, 50/60Hz input power
- Auto power limiting protection circuit
- One week. clock retention for power outages

Controller Overview

The Variable Speed Pump uses a premium efficiency variable speed motor that provides tremendous program flexibility in terms of motor speed and duration settings. The pump is intended to run at the lowest speeds needed to maintain a sanitary environment, which in turn minimizes energy consumption. Pool size, the presence of additional water features, chemicals used to maintain sanitary conditions, and local environmental factors will impact optimal programming necessary to maximize energy conservation.



This pump is for use with 230 Vrms nominal, and in pool pump applications ONLY.

Connection to the wrong voltage, or use in other application may cause damage to equipment or personal injury.

The integrated electronics interface controls the speed settings as well as the run durations. The pump can operate at speeds ranging between 450 and 3450 RPM and will operate within the voltage range of 230 Vrms at either 50 or 60Hz input frequency. Program customization may require some trial-and-error to determine the most satisfactory settings as dictated by the conditions. In most cases, setting the pump at the lowest speed for the longest duration is the best strategy to minimize energy consumption. However, conditions may require running the pump at a higher speed for some duration of time each day to maintain proper filtration to achieve satisfactory sanitation.

Note: Optimize the pump to suit individual pool conditions. Specific conditions including pool size, other devices, features and environmental factors can all impact the optimal settings.

CONTROL PANEL OVERVIEW

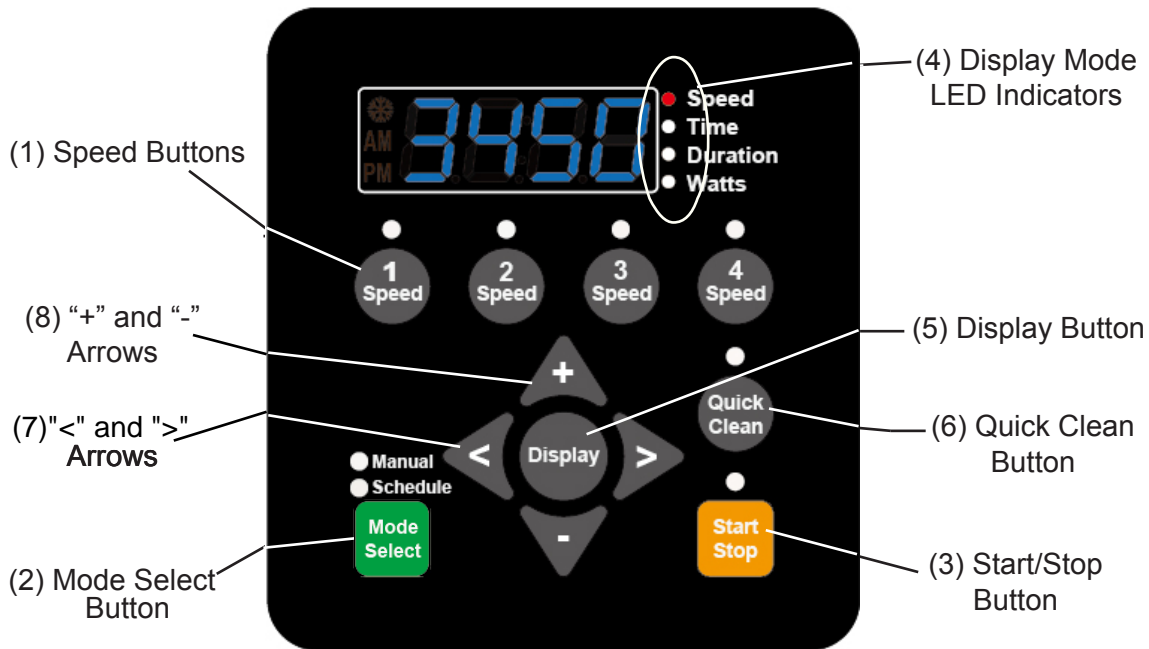

CAUTION

If power is connected to the Variable Speed Pump motor, pressing any of the following buttons referred to in this section could result in the motor starting. Failure to recognize this could result in personal injury or damage to equipment.

Keypad Navigation

1. **Speed Buttons** - Used to select the run speed desired. The LED above the Speed Buttons will illuminate when that speed is selected or is currently running. A flashing LED indicates is active on that speeds channel.
2. **Mode select Button** - Choose manual and schdule
3. **Start/Stop Button** - Used to Start and Stop the pump. When the pump is stopped and the LED is not illuminated, the pump is unable to run from any type of input.
4. **Display Mode LED Indicators** - An illuminated LED indicates the information being displayed on the screen at any specific point. A flashing LED indicates that the parameter is currently being edited.
5. **Display Button** - Used to toggle between the different available display modes. This button is also used to set the 24-hour clock and screen resolution.
6. **Quick Clean Button** - Used to run a selected speed and duration programmed for Quick Clean. When the LED is illuminated the Quick Clean schedule is active.
7. **"<" and ">" Arrows**- Choose between a 12 or 24 hour time format
8. **"+" and "-" Arrows** -Used to make on screen adjustments to the pump settings. The "+" arrow increases the value of a given setting, while "-" decreases the value of a given setting. Pressing and holding down either arrow button will increase or decrease the incremental changes faster.

INSTALLATION

Only a qualified plumbing professional should install the Variable Speed Pump. Refer to “*Pump Warning And Safety Instructions*” on pages ii-iii for additional installation and safety information.

Location

Note: Do not install this pump within an outer enclosure or beneath the skirt of a hot tub or spa unless marked accordingly.

Note: Ensure that the pump is mechanically secured to the equipment pad.

Be sure the pump location meets the following requirements:

1. Install the pump as close to the pool or spa as possible. To reduce friction loss and improve efficiency, use short, direct suction and return piping.
2. Install a minimum of 5 feet (1.52 meters) from the inside wall of the pool and spa. Canadian installations require a minimum of 9.8 feet (3 meters) from the inside wall of the pool.
3. Install the pump a minimum of 3 feet (.9 meters) from the heater outlet.
4. Do not install the pump more than 10 feet (3.1 meters) above the water level.
5. Install the pump in a well ventilated location protected from excess moisture (i.e. rain gutter downspouts, sprinklers, etc.).
6. Install the pump with a rear clearance of at least 3 inches (7.6 cm) so that the motor can be removed easily for maintenance and repair. See **Figure 1**.

Piping

1. For improved pool plumbing, it is recommended to use a larger pipe size.
2. Piping on the suction side of the pump should be the same or larger than the return line diameter.
3. Plumbing on the suction side of the pump should be as short as possible.
4. For most installations Pentair recommends installing a valve on both the pump suction and return lines so that the pump can be isolated during routine maintenance. However, we also recommend that a valve, elbow or tee installed in the suction line should be no closer to the front of the pump than five (5) times the suction line diameter. See **Figure 2**.

Example: A 2.5 inch pipe requires a 12.5 inch (31.8 cm) straight run in front of the suction inlet of the pump. This will help the pump prime faster and last longer.

Note: DO NOT install 90° elbows directly into the pump inlet or outlet.

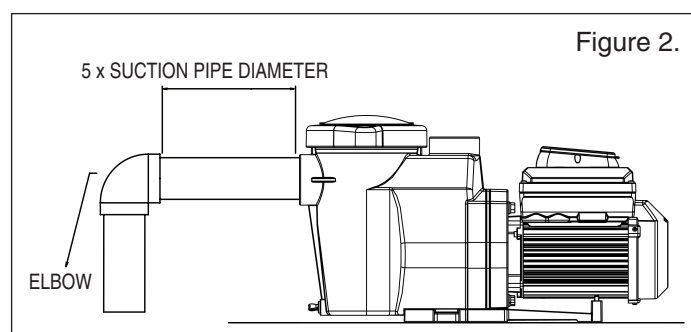
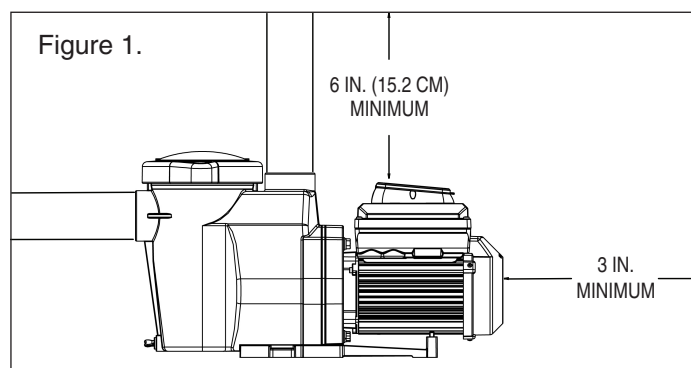

Fittings and Valves

1. Do not install 90° elbows directly into pump inlet.
2. Flooded suction systems should have gate valves installed on suction and discharge pipes for maintenance, however, the suction gate valve should be no closer than five times the suction pipe diameter as described in this section.
3. Use a check valve in the discharge line when using this pump for any application where there is significant height to the plumbing after the pump.
4. Be sure to install check valves when plumbing in parallel with another pump. This helps prevent reverse rotation of the impeller and motor.

Electrical Requirements

- Install all equipment in accordance with the National Electrical code and all applicable local codes and ordinances.
- A means for disconnection must be incorporated in the fixed wiring in accordance with the wiring rules.

WARNING

RISK OF ELECTRICAL SHOCK OR ELECTROCUTION. The Variable Speed Pump must be installed by a licensed or certified electrician or a qualified service professional in accordance with the National Electrical Code and all applicable local codes and ordinances. Improper installation will create an electrical hazard which could result in death or serious injury to users, installers, or others due to electrical shock, and may also cause damage to property.

Always disconnect power to the pump at the circuit breaker before servicing the pump. Failure to do so could result in death or serious injury to service people, pool users or others due to electric shock and/or property damage.
Read all servicing instructions before working on the pump.

Wiring Overview and Installation

WARNING

Power should be turned off when installing, servicing, or repairing electrical components.

Observe all warning notices posted on the existing equipment, pump, and in these installation instructions.

The pump must be wired according to the local electrical codes and standards. Always refer to the National Electrical Code. This pump should be installed by a licensed electrician.

The pump accepts 230V, 50 or 60Hz single phase input power. The terminal block connections are capable of handling up to 12AWG solid or stranded wire. There are also fast-on type quick connectors, however, check the local electrical codes for the desired connection method. The connections must be permanently made to the grounding terminal (see **Figure 3**) in the field wiring compartment according to the local electrical code.

The drive will operate on 2-phase Line-Line-Ground electrical systems as well as Line-Neutral-Ground systems. This pump must be permanently connected by a circuit breaker as specified in the local electrical code.

1. Be sure all electrical breakers and switches are turned off before wiring motor. Always wait five (5) minutes after disconnecting the power from the pump before opening or servicing the drive.
2. Choose a wire size for the pump in accordance with the current National Electrical Code and all applicable local codes and ordinances. When in doubt use a heavier gauge (larger diameter) wire. Be sure the wiring voltage is within the operating range.
3. Be sure all electrical connections are clean and tight.
4. Cut wires to the appropriate length so they do not overlap or touch when connected to the terminal board.
5. Permanently ground the motor using the ground screw located on the inside rear of the controller interface (see **Figure 3**). Use the correct wire size and type specified by the current National Electrical Code. Be sure the ground wire is connected to an electrical service ground.

6. Bond the motor to all metal parts of the pool structure and to all electrical equipment, metal conduit and metal pipping within 5 feet (1.5 M) of the inside walls of the swimming pool, spa or hot tub in accordance with the current National Electrical Code. UL requires use of a solid copper bonding conductor not smaller than 8 AWG. See **Figure 3**.

Note: For Canada, a 6 AWG or larger solid copper bonding conductor is required.

7. The pump should be permanently connected to either a circuit breaker, 2-pole timer or 2-pole relay. If AC power is supplied by a GFCI circuit breaker, use a dedicated circuit breaker that has no other electrical loads.
8. Connect the pump permanently to a circuit. Make sure no other lights or appliances are on the same

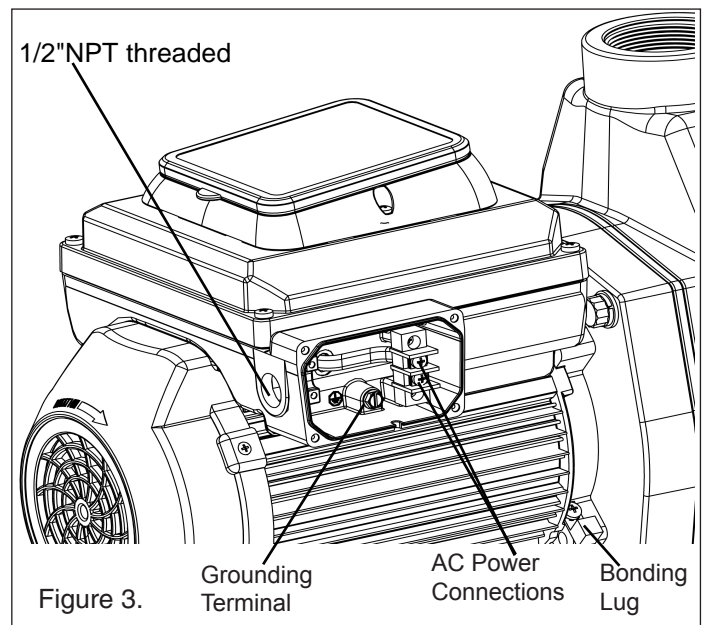

Figure 3.

The field wiring compartment has a 1/2" NPT threaded conduit port for the liquid tight fitting.

The bonding lug should be used to bond the motor frame to the equipment pad.

OPERATING THE PUMP

Setting the Clock

When the pump is first installed, it is necessary to set the clock. Any daily schedule set by the user must be based on accurate time setting.

To Set the Clock:

1. When the pump is plugged in, the TIME led light is blinking. Entering clock setup by pushing Display key.
(Time setup will be unavailable after 5 seconds' blinking. Note: Pump must be plugged out and ensure the lights on panel all go out, then re-plug it to enter the setup and operate step 1.)
2. Use the "<" and ">" arrows to choose between a 12 or 24 hour time format.
3. Use the "+" and "-" arrows to change the time to the correct time of day. In the 12 hour time format AM/PM will display in the bottom left corner.
4. Press **Display** to exit the Clock Setup menu. The clock is now set.

During a power outage, the drive will retain the clock setting in memory for as long as one week. If the power is out longer than one week the clock will have to be set again. **(Pump must be plugged out and ensure the lights on panel all go out, then re-plug it to enter the setup and operate step 1.)**

Note: When power is returned to the pump after a prolonged outage (one week) the clock will automatically set itself to the Speed 1 start time, blink and advance. The pump will also run the associated schedule from that start time.

Using the Default Schedule

The default schedule is designed to provide enough daily turnover to service a typical pool. See **Table 2** for default schedule.

	Duration (Hours)	Speed (RPM)
SPEED 1	2	3000
SPEED 2	10	1500
SPEED 3	2	2500
SPEED 4	4	1000

Table 2: Default Schedule.

SPEED 1 is set to begin at 8:00am and run at 3000 RPM for a duration of 2 hours. When SPEED 1 is complete the pump immediately begins running the default SPEED 2. SPEED 2 is factory default to 1500 RPM and will last for 10 hours. When SPEED 2 has completed its run the pump will run SPEED 3 at 2500 RPM for a duration of two hours. When SPEED 3 has completed its run the pump will run SPEED 4 at 1000 RPM for a duration of four hours.

After 18 hours of run time and completing its run of SPEED 4, the pump will enter a stationary/paused state for the next 6 hours. The pump will restart at 8:00am the next morning and cycle through the default schedule again. The pump will continue to run in this manner until a custom schedule is programmed into the drive by the user.

Note: The **Start/Stop** button must be pressed, and the LED lit, for the pump to run.

SPEED 1 AND PRIMING

The installer should set the priming speed to be sufficient for priming the pump from a fresh install, but not so fast that there is a substantial waste of energy. The time the pump needs to achieve prime can change based on local environmental conditions such as water temperature, atmospheric pressure, and your pool's water level. All of these things should be taken into consideration when setting the priming speed, however in most cases the pump will not need to run at 3450 RPM to successfully prime itself.

Please test and verify chosen priming speeds more than once, letting the water drain from the system in between each test. Turn on pump and switch to Manual mode to test Priming by operating SPEED 1. Take note of the time that the water filled the PUMP HOUSING, then stop the pump. Re-start the pump to set the SPEED 1/Priming duration.

Custom Schedules and Quick Clean

To customize the run schedule for your Variable Speed Pump, the pump must be stopped. Be sure that the **Start/Stop** button LED is not illuminated.

Programming a Custom Schedule:

Note: When programming, the LED light next to the parameter (“Speed”, “Time” and “Duration”) you are setting will blink.

1. Stop the pump if it is running by pressing the **Start/Stop** button.
2. Press the “1” button. The LED above the selected SPEED will begin to blink and the “Speed” parameter LED will blink while editing. See **Figure 7**.



Figure 7: Setting Speed

3. Use the “+” and “-” arrows to adjust the speed in RPM for SPEED 1.

Note: Speed is adjusted up or down by increments of 10 RPM.
4. Press the “1” button again and the display will change to SPEED 1 start time. The “Time” parameter LED will begin to blink. See **Figure 8**.



Figure 8: Setting Start Time

5. Use the “+” and “-” arrows to adjust the daily start time for SPEED 1.

6. Press the “1” button again and the display will change to SPEED 1 duration. The “Duration” parameter LED will begin to blink. See **Figure 9**.



Figure 9: Setting Duration

7. Use the “+” and “-” arrows to adjust the duration for SPEED 1 in hours and minutes.

Note: The duration parameter is adjusted in 15 minute increments.
8. Pressing the “1” button will continue to cycle through these parameters, but the changes are immediately saved as they are adjusted.
9. Press the “2” button. The LED above SPEED 2 will begin to flash and the corresponding parameter LED will flash while editing.
10. Use the “+” and “-” arrows to adjust the speed in RPM for SPEED 2.
11. Press the “2” button again and the display will change to SPEED 2 duration.

Note: SPEEDs 2 and 3 do not have a start time, as they begin their duration immediately after the previous SPEED finishes.
12. Use the “+” and “-” arrows to adjust the duration for SPEED 2 in hours and minutes.
13. Repeat steps 9-12 to program SPEED 3-4 and QUICK CLEAN.

Note: Remember that the duration allowed for SPEED 3 will be limited to the remaining time in a 24 hour day. Any time in the 24 hour day not programmed into SPEEDs 1-4, the pump will remain in a stationary state.
[$SPEED\ 1 + SPEED\ 2 + SPEED\ 3 + SPEED\ 4 < 24\ Hours$]
14. Press the **Start/Stop** button and ensure the LED is lit. The pump is now on and will run the custom user-programmed schedule.

Note: If the pump has been stopped via the **Start/Stop** button, the pump will not run until the pump is turned back on by the **Start/Stop** button. If the **Start/Stop** LED is illuminated then the pump is on and will run the programmed schedule.

Speed Priorities

For schedule duration settings, SPEEDS are prioritized as follows: SPEED 1 -> SPEED 2 -> SPEED 3 -> SPEED 4. SPEED 1 is the highest priority, while SPEED 4 is the lowest.

The drive will not allow a user to program a schedule of more than 24 hours. When the 24th hour of duration is programmed it will take time from the lower priority speeds in order to add them to the SPEED currently being adjusted.

Example:

Starting Schedule (Before Adjustment)

SPEED 1 duration = 18 hours
 SPEED 2 duration = 2 hours
 SPEED 3 duration = 2 hours
 SPEED 4 duration = 2 hours

If the user reprograms SPEED 1 to run for 22 hours, SPEED 2 (lower priority speed) will automatically adjust to a 1 hour duration and SPEED 4 (lowest priority speed) will adjust to a 0 hour duration.

End Schedule (After Adjustment)

SPEED 1 duration = 22 hours
 SPEED 2 duration = 1 hour
 SPEED 3 duration = 1 hours
 SPEED 4 duration = 0 hours

Operating the Pump While Running

CAUTION

If power is connected to the pump motor, pressing any of the following buttons referred to in this section could result in the motor starting. Failure to recognize this could result in personal injury or damage to equipment.

Pressing the **Display** button will cycle through the current parameters.

- **Speed** — current run speed
- **Time** — current time of day
- **Duration** — amount of time remaining at the current run speed
- **Watts** — amount of watts currently being consumed

Pressing any of the Speed Buttons (“1”, “2”, “3”, “4”, “**Quick Clean**”) while the pump is running will act as temporary override. It will run the speed and duration that is programmed for that button. Once completed it will default back to the appropriate point in the programmed schedule.

Note: If you adjust the speeds of the schedule while the pump is running, it will run the adjusted speed for the rest of the current duration, but will not save the adjustments.

MAINTENANCE



WARNING

DO NOT open the strainer pot if Variable Speed Pump fails to prime or if pump has been operating without water in the strainer pot. Pumps operated in these circumstances may experience a build up of vapor pressure and may contain scalding hot water. Opening the pump may cause serious personal injury. In order to avoid the possibility of personal injury, make sure the suction and discharge valves are open and strainer pot temperature is cool to touch, then open with extreme caution.



CAUTION

To prevent damage to the pump and for proper operation of the system, clean pump strainer and skimmer baskets regularly.

Pump Strainer Basket

The pump strainer basket (or 'strainer pot', 'hair and lint pot'), is located in front of the volute. Inside the chamber is the basket which must be kept clean of leaves and debris at all times. View basket through the 'See Through Lid' to inspect for leaves and debris.

Regardless of the length of time between filter cleaning, it is most important to visually inspect the basket at least once a week.

Cleaning the Pump Strainer Basket

1. Press the **Start/Stop** button to stop the pump and turn off the pump at the circuit breaker.
2. Relieve pressure in the system by allowing the water to cool.
3. Gently tap the clamp in a counter-clockwise direction to remove the clamp and lid.
4. Remove debris and rinse out the basket. Replace the basket if it is cracked.
5. Put the basket back into the housing. Be sure to align the notch in the bottom of the basket with the rib in the bottom of the volute.
6. Fill the pump pot and volute up to the inlet port with water.
7. Clean the cover, O-ring, and sealing surface of the pump pot. **Note:** It is important to keep the lid O-ring clean and well lubricated.
8. Reinstall the lid by placing the lid on the pot. Be sure the lid O-ring is properly placed. Seat the clamp and lid on the pump then turn clockwise until the handles are horizontal.
9. Turn the power on at the house circuit breaker. Reset the pool time clock to the correct time, if applicable.
10. Open the manual air relief valve on top of the filter.
11. Stand clear of the filter. Start the pump.
12. Bleed air from the filter until a steady stream of water comes out. Close the manual air relief valve.



WARNING

THIS SYSTEM OPERATES UNDER HIGH PRESSURE. When any part of the circulating system (e.g., Lock Ring, Pump, Filter, Valves, etc.) is serviced, air can enter the system and become pressurized. Pressurized air can cause the lid to separate which can result in serious injury, death, or property damage. To avoid this potential hazard, follow above instructions.



Winterizing

You are responsible for determining when freezing conditions may occur. If freezing conditions are expected, take the following steps to reduce the risk of freeze damage. **Freeze damage is not covered under warranty.**

To prevent freeze damage, follow the procedures below:

1. Press the **Start/Stop** button to stop the pump and shut off electrical power for the pump at the circuit breaker.
2. Drain the water out of the pump housing by removing the two thumb-twist drain plugs from the housing. Store the plugs in the pump basket.
3. Cover the motor to protect it from severe rain, snow and ice.

Note: Do not wrap motor with plastic or other air tight materials during winter storage. The motor may be covered during a storm, winter storage, etc., but never when operating or expecting operation.

Note: In mild climate areas, when temporary freezing conditions may occur, run your filtering equipment all night to prevent freezing.

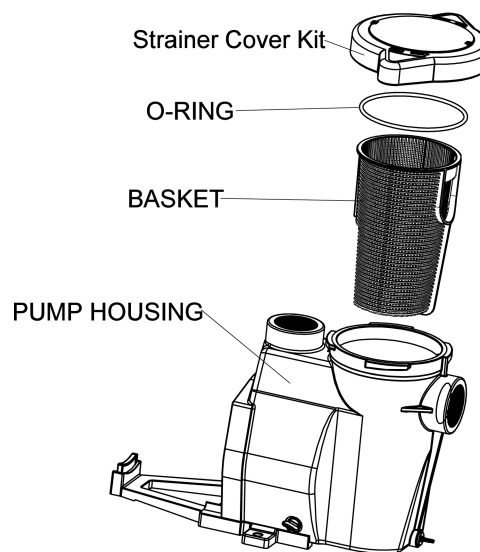

Strainer Pot Assembly

SERVICING

WARNING Always disconnect power to the Variable Speed Pump at the circuit breaker and disconnect the communication cable before servicing the pump. Failure to do so could result in death or serious injury to service people, users or others due to electric shock. Read all servicing instructions before working on the pump.

WARNING **DO NOT** open the strainer pot if pump fails to prime or if pump has been operating without water in the strainer pot. Pumps operated in these circumstances may experience a build up of vapor pressure and may contain scalding hot water. Opening the pump may cause serious personal injury. In order to avoid the possibility of personal injury, make sure the suction and discharge valves are open and strainer pot temperature is cool to touch, then open with extreme caution.

CAUTION Be sure not to scratch or mar the polished shaft seal faces; seal will leak if faces are damaged. The polished and lapped faces of the seal could be damaged if not handled with care.

Electric Motor Care

Protect from heat

1. Shade the motor from the sun.
2. Any enclosure must be well ventilated to prevent overheating.
3. Provide ample cross ventilation.

Protect against dirt

1. Protect from any foreign matter.
2. Do not store (or spill) chemicals on or near the motor.
3. Avoid sweeping or stirring up dust near the motor while it is operating.
4. If a motor has been damaged by dirt it may void the motor warranty.
5. Clean the lid and clamp, O-ring, and sealing surface of the pump pot.

Protect against moisture

1. Protect from splashing or sprayed water.
2. Protect from extreme weather such as flooding.
3. If motor internals have become wet - let them dry before operating. Do not allow the pump to operate if it has been flooded.
4. If a motor has been damaged by water it may void the motor warranty.

Shaft Seal Replacement

The Shaft Seal consists primarily of two parts, a rotating member and a ceramic seal.

The pump requires little or no service other than reasonable care, however, a Shaft Seal may occasionally become damaged and must be replaced.

Note: The polished and lapped faces of the seal could be damaged if not handled with care.

Pump Disassembly

All moving parts are located in the rear sub-assembly of this pump.

Tools required:

- 3/8 inch socket or open end wrench.
- Phillips screwdriver
- Flat blade screwdriver.

To remove and repair the motor subassembly, follow the steps below:

1. Press the **Start/Stop** button to stop the pump and turn off the pump circuit breaker at the main panel.
2. Drain the pump by removing the drain plugs.
3. Remove the 4 bolts that hold the main pump body (strainer pot/volute) to the rear sub-assembly.
4. GENTLY pull the two pump halves apart, removing the rear sub-assembly.
5. To unscrew the impeller from the shaft, insert a Phillips screwdriver into the hole of the motor fan and twist the impeller counter-clockwise. See **Figure 10**.

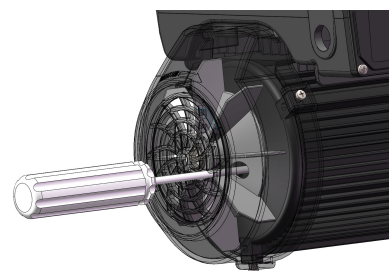

Figure 10

6. Place the seal plate face down on a flat surface and tap out the ceramic seal.
7. Remove the graphite seal ring on the impeller shaft.
8. Clean the seal plate, seal housing, and the impeller shaft.

CAUTION **DO NOT run the pump dry.** If the pump is run dry, the mechanical seal will be damaged and the pump will start leaking. If this occurs, the damaged seal must be replaced. ALWAYS maintain proper water level. If the water level falls below the suction port, the pump will draw air through the suction port, losing the prime and causing the pump to run dry, resulting in a damaged seal. Continued operation in this manner could cause a loss of pressure, resulting in damage to the pump case, impeller and seal and may cause property damage and personal injury.

Pump Reassembly

1. When installing the replacement seal into the seal plate, use soapy water to wet the rubber boot before pressing it into the seal plate.
2. Remount the seal plate to the motor mounting plate.
3. Before installing the rotating part of the seal on the impeller shaft, wet the impeller shaft with soapy water and slide the seal to the impeller shaft end. Remove the dirt from the contact surface of the seal with a clean cloth.
4. Screw impeller onto the motor shaft (clockwise to tighten).
Note: Insert a Phillips screwdriver into the hole of the motor fan.
5. Remount the diffuser onto the seal plate.
6. Grease the diffuser quad ring and seal plate O-ring prior to reassembly.
7. Assemble the motor sub-assembly to the strainer pot-pump body. Tighten the bolts until all 4 bolts are in place and finger tightened.
8. Fill the pump with water.
9. Reinstall the pump lid and plastic clamp; see the next section, 'Restart Instructions'.
10. Re-prime the system.

Restart Instructions

If Variable Speed Pump is installed below the water level of the pool, close return and suction lines prior to opening hair and lint pot on pump. Make sure to re-open valves prior to operating.

Priming the Pump

The pump strainer pot must be filled with water before the pump is initially started.

Follow these steps to prime the pump:

1. Remove the pump lid plastic clamp. Remove the pump lid.
2. Fill the pump strainer pot with water.
3. Reassemble the pump cover and plastic clamp onto the strainer pot. The pump is now ready to prime.
4. Open the air release valve on the filter, and stand clear of the filter.
5. Turn on the power to the pump.
6. Press the **Start/Stop** button on the drive keypad. If the pump is currently scheduled to run it will start.
Note: If the pump is not schedule to start, press a **Speed** button to begin a manual override that will start the pump.
7. When water comes out of the air release valve, close the valve. The system should now be free of air and recirculating water to and from the pool.

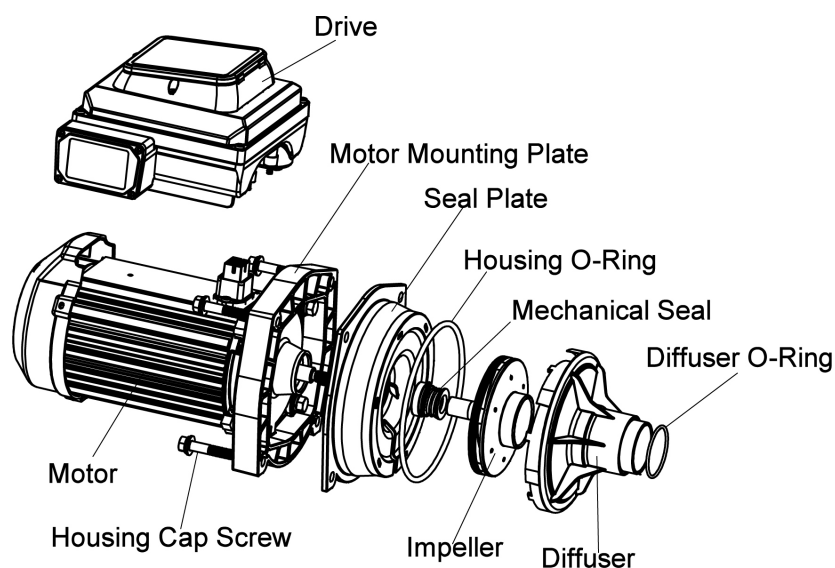

TROUBLESHOOTING



WARNING Diagnosing certain symptoms may require close interaction with, or in close proximity to, components that are energized with electricity. Contact with electricity can cause death, personal injury, or property damage. When trouble shooting the pump, diagnostics involving electricity should be cared for by a licensed professional.

Problem	Possible Cause	Corrective Action
Pump failure.	<p>Pump will not prime - Air leak, too much air.</p> <p>Pump will not prime - Not enough water.</p> <p>Pump stainer gasket is clogged.</p> <p>Pump strainer gasket is defective.</p>	<p>Check suction piping and valve glands on any suction gate valves. Secure lid on pump strainer pot and be sure lid gasket is in place. Check water level to be sure skimmer is not drawing air.</p> <p>Be sure the suction lines, pump, strainer, and pump volute are full of water. Be sure valve on suction line is working and open (some systems do not have valves). Check water level to make sure water is available through skimmer.</p> <p>Clean pump strainer pot.</p> <p>Replace gasket.</p>
Reduced capacity and/or head.	<p>Air pockets or leaks in suction line.</p> <p>Clogged impeller.</p> <p>Pump strainer clogged.</p>	<p>Check suction piping and valve glands on any suction gate valves. Secure lid on pump strainer pot and be sure lid gasket is in place. Check water level to be sure skimmer is not drawing air.</p> <p>Turn off electrical power to the pump. Disassemble (see page 14, 'Pump Disassembly')</p> <p>Clean debris from impeller. If debris cannot be removed, complete the following steps: 1. Remove left hand thread anti-spin bolt and o-ring. 2. Remove, clean, and reinstall impeller. Reassemble (see page 15, 'Pump Reassembly')</p> <p>Clean suction trap.</p>
Pump fails to start.	<p>Mains Voltage is not present</p> <p>Pump shaft is locked</p> <p>Pump shaft is damaged</p>	<p>1. Replace fuse, reset breaker/GFCI. 2. Tighten mains wire connections.</p> <p>Check if the pump can be rotated by hand and remove any blockage.</p> <p>Replace pump.</p>
Pump runs then stops.	<p>Over temperature FAULT</p> <p>Over current FAULT</p>	<p>Check that back of pump is free from dirt and debris. Use compressed air to clean.</p> <p>Pump will automatically restart after one (1) minute.</p>
Pump is noisy.	<p>Debris in contact with fan</p> <p>Debris in strainer basket</p> <p>Loose mounting</p>	<p>Check that back of pump is free from dirt and debris. Use compressed air to clean.</p> <p>Clean strainer basket.</p> <p>Check that mounting bolts of pump and pump are tight.</p>

Troubleshooting (Cont.)

Problem	Possible Cause	Corrective Action
Pump runs without flow.	Impeller is loose	Check that pump is spinning by looking at fan on back of Variable Speed Pump. If so, check that pump impeller is correctly installed.
	Air leak	Check plumbing connections and verify they are tight.
	Clogged or restricted plumbing	Check for blockage in strainer or suction side piping. Checked for blockage in discharge piping including partially closed valve or dirty pool filter.

Errors and Alarms

If an alarm is triggered the drive's LCD screen will display the fault code text and the Variable Speed Pump will stop running. Disconnect power to the pump and wait until the keypad LEDs have all turned off. At this point, reconnect power to the pump. If the error has not cleared then proper troubleshooting will be required. Use the error description table below to begin troubleshooting.

Fault Code	Description	Fault Code	Description
E-01	Inverter unit protection	E-11	Phase loss at input side
E-02	Acceleration over current	E-12	Phase failure at output side
E-03	Deceleration over current	E-14	Module overheating
E-04	Constant speed over current	E-16	Communication fault
E-05	Acceleration over voltage	E-17	Current detection fault
E-06	Deceleration over voltage	E-24	Inverter hardware fault
E-07	Constant speed over voltage		
E-08	Under voltage fault		
E-09	Motor overload		
E-10	Inverter overload		

E-16– Communication Link between the HMI and Motor control has been lost: Check the jacketed wire on the back side of the keypad inside the drive top cover. Ensure that the 5 pin connector is properly plugged into the socket and that there is no damage to the cable.

E-01,02,03,04,05,06,07,09,10,24– Internal Errors: If this error displays multiple times, then there may be a problem with the pump's rotating assembly. Please disassemble the pump and investigate to see if there is a problem with the impeller or mechanical seal. See page 9 "Pump Disassembly" for instructions for disassembling the pump.

E-08– Absolute AC Under Voltage Detected: This indicates that the supply voltage has dropped below the operating range of 200v. This could be caused by normal voltage variation and will clear itself. Otherwise there could be excess voltage sag caused by improper installation or improper supply voltage.

E-14- Module overheating: Should be caused by high ambient temperature or overload

Pump Performance Curves

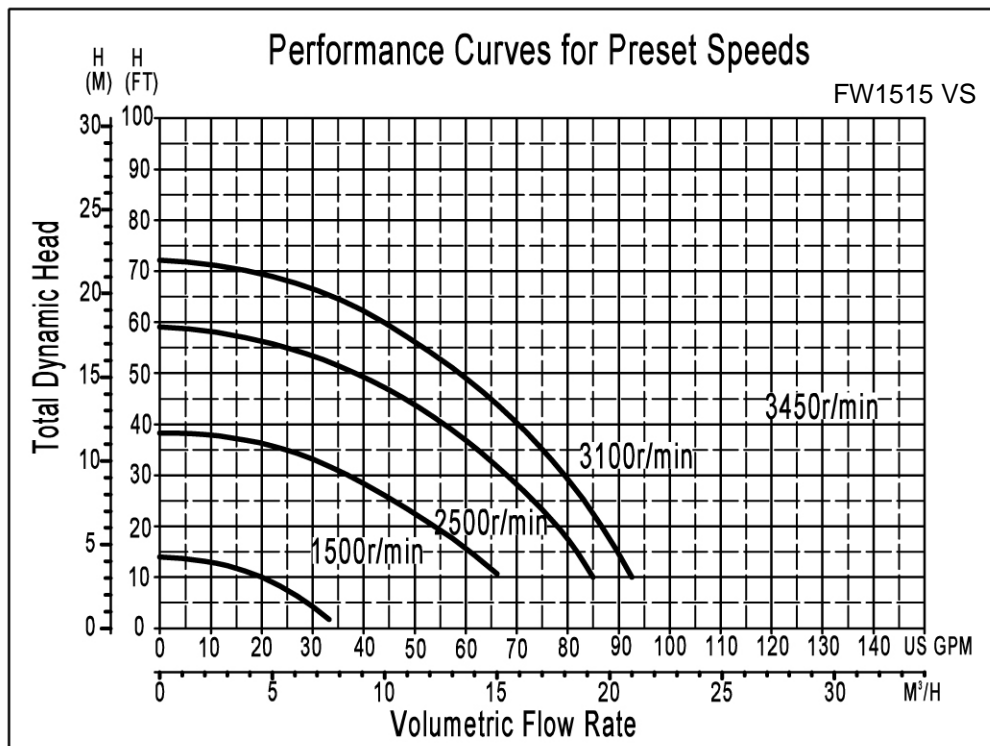

Model Specifications

Overall Ratings

Model	FW1515 VS
Input Voltage	230 V
Input Frequency	Single phase, 50 or 60 Hz
Input Current	5.6A
Maximum Continuous Load	1.5HP
Speed Range	450 - 3450 RPM
Environmental Rating	NEMA Type 3
Port Size	1.5"x1.5"

Pump Dimensions

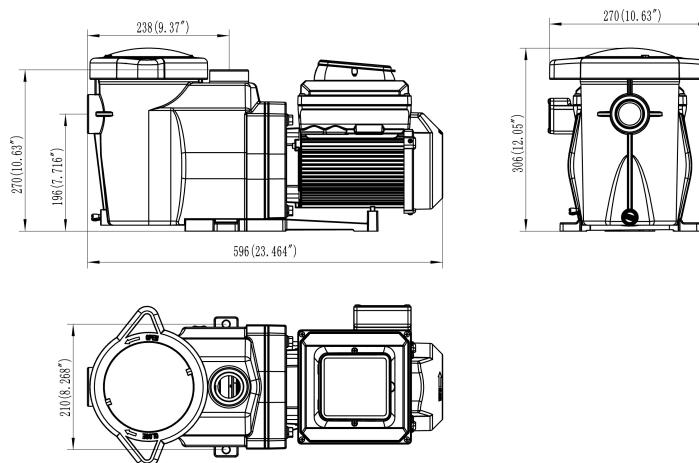

Pump Performance Curves

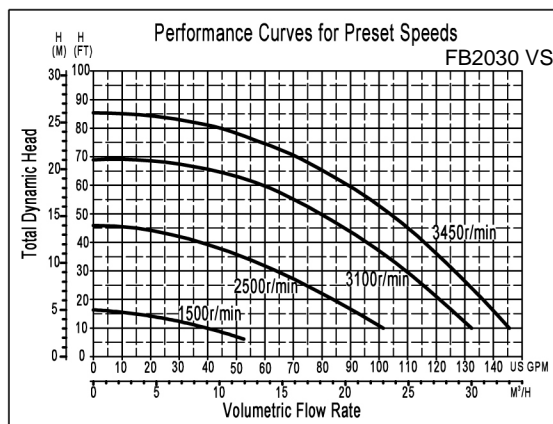
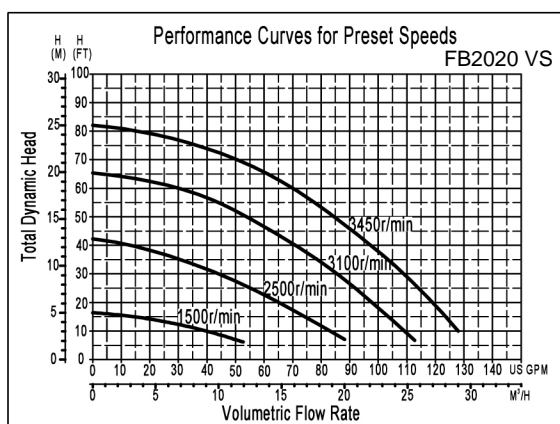
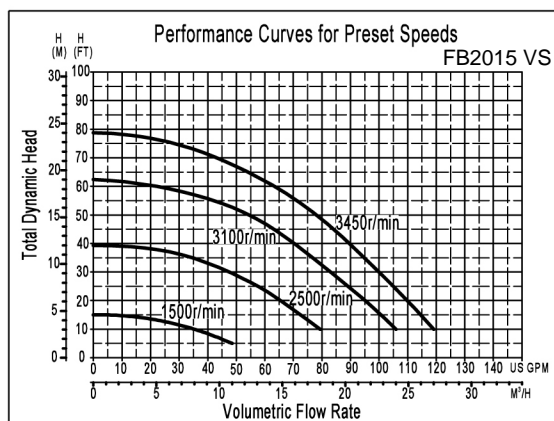
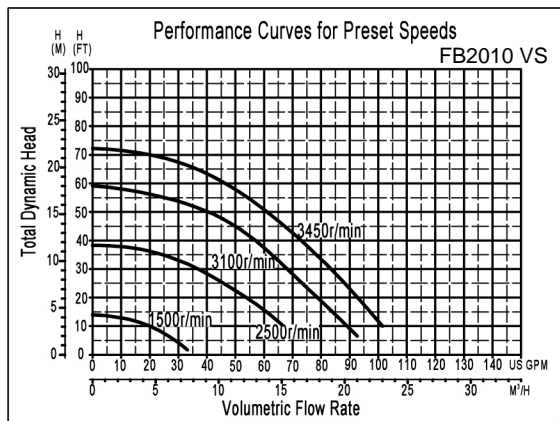

Pump Dimensions

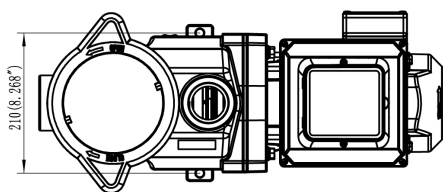
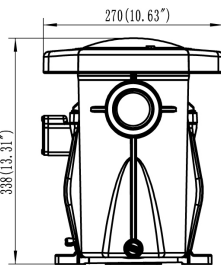
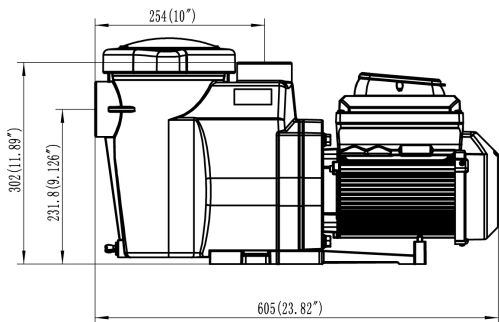

Model Specifications

Overall Ratings

Model	FB2010 VS	FB2015VS	FB2020VS	FB2030 VS
Input Voltage	230 V			
Input Frequency	Single phase, 50 or 60 Hz			
Input Current	5.5A	7A	8A	10A
Maximum Continuous Load	1HP	1.5HP	2HP	3HP
Speed Range	450 - 3450 RPM			
Environmental Rating	NEMA Type 3			
Port Size	2"x2"			