

SPP POOL PUMP

INSTRUCTION MANUAL



**READ THIS MANUAL CAREFULLY
BEFORE USING YOUR SPP PUMP**

SPP PUMP PARTS BREAKDOWN

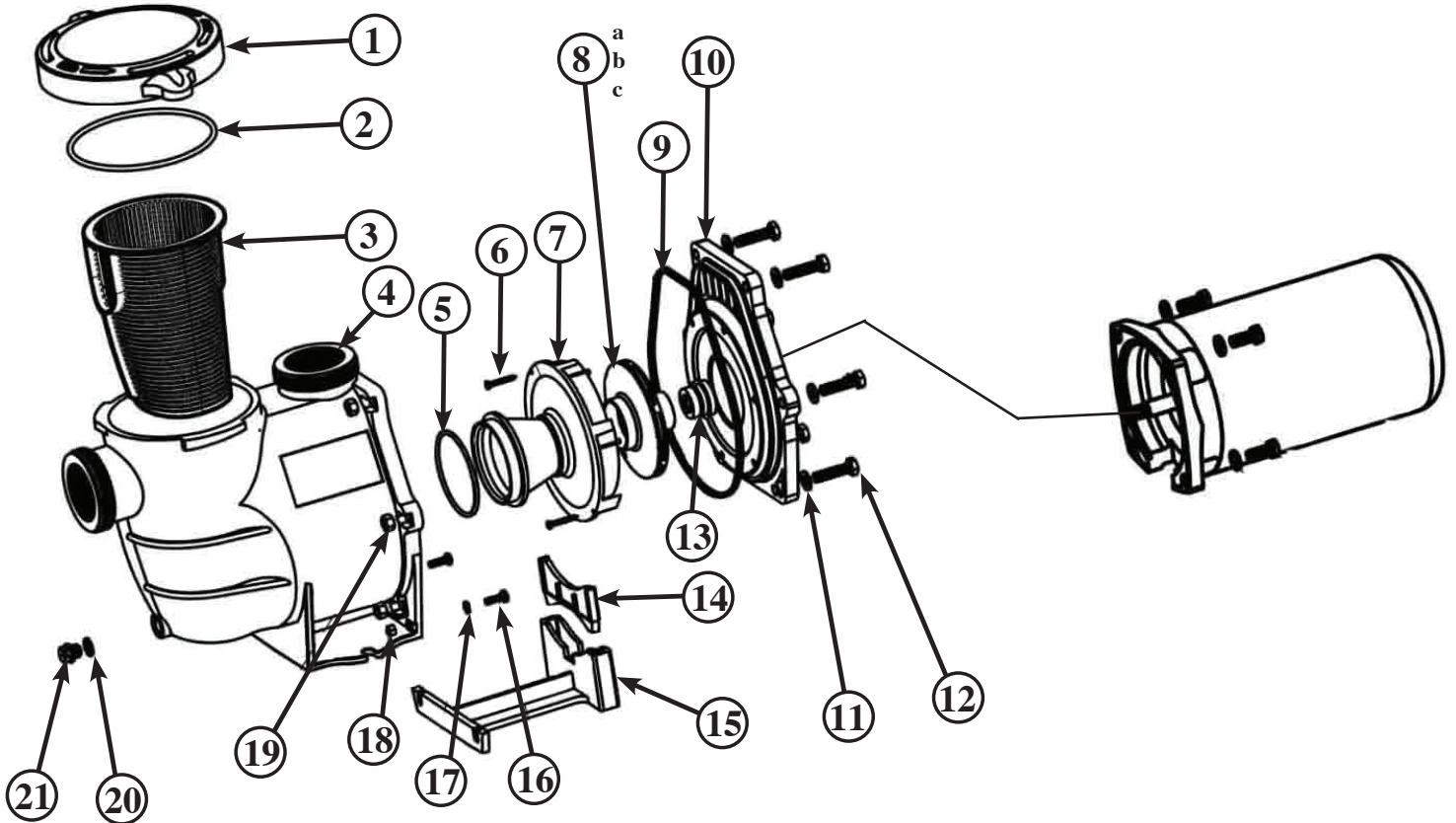

PART #	MODEL #	DESCRIPTION	1000 SPP	1500 SPP	2000 SPP
1	AC 81361	Pump Lid	1	1	1
2	AC 81396	Pump Lid O-Ring	1	1	1
3	AC 81434	Pump Basket	1	1	1
4	AC 81937	Strainer Casing	1	1	1
5	AC 81477	Diffuser O-Ring	1	1	1
6	AC 82015	Diffuser Screws	1	1	1
7	AC 82333	Diffuser	1	1	1
8A	AC 84468	Impeller 1 HP	1	1	1
8B	AC 82538	Impeller 1.5 HP	1	1	1
8C	AC 82546	Impeller 2 HP	1	1	1
9	AC 82565	Casing O-Ring	1	1	1
10	AC 82589	Seal Plate	1	1	1
11	AC 82597	Housing Washer	10	10	10
12	AC 82600	Housing Bolts	6	6	6
13	AC 82619	Seal Plate	1	1	1
14	AC 82627	Base Bracket	8	8	8
15	AC 82643	Base Support	1	1	1
16	AC 82651	Base Bolt	2	2	2
17	AC 82649	Base Bolt Washer	2	2	2
18	AC 85847	Base Bolt Nut	1	1	1
19	AC 82724	Casing Nut	6	6	6
20	AC 81590	Drain Plug O-Ring	1	1	1
21	AC 81620	Drain Plug	1	1	1

IMPORTANT SAFETY INSTRUCTIONS

NOTE All wiring should be done by a qualified electrician in accordance to the National Electric Code and all Local Codes and ordinances.

When installing and using this electrical equipment, basic safety precautions should ALWAYS be followed.

READ AND FOLLOW ALL INSTRUCTIONS



WARNING

1. To reduce the risk of injury, do not allow children to use this equipment
2. Connect only to a grounding type receptacle that is protected by a ground fault circuit interrupter (GFCI).
3. Do not connect this equipment to an extension cord. To reduce the risk of electric shock, only connect the electric cord to a properly located outlet.
4. To reduce the risk of shock, connect ground wires to the grounding screw located in the motor.
5. To reduce the risk of shock, a bonding connector is provided for bonding to any metal within 5 feet of the swimming pool. All local points should be bonded with #8AWG (8.4mm²) wire.

NOTE To installer and/or operator of the SPP swimming pool pump: the manufacturer's warranty will be void if the pump is improperly installed and/or operated.

OPERATION AND MAINTENANCE

PUMP LOCATION

1. Locate the pump on a level surface as close to the pool as practical. Consult local codes for minimum distances between pool and pump if applicable.
2. The connection plumbing (hose or rigid pipe) should be direct and as free from turns and bends as possible. Take care not to kink flexible hose. Elbows and other fittings greatly increase friction losses.
3. Place pump on a solid foundation / base which provides a rigid and vibration free support.
4. Protect the pump against flooding and excess moisture. Protect the motor from foreign objects clogging the air circulation around the motor.
5. **NEVER** use gasoline or other flammable liquids or vapors in the vicinity of this pump.

NOTE DO NOT store pool chemicals near this pump.
DO NOT remove any safety labels such as CAUTION / DANGER / WARNING from this pump. Keep labels in good condition and replace any damaged labels.



WARNING

Keep labels in good condition and replace any damaged labels

PUMP INSTALLATION

1. When connecting plumbing fittings to the pumps threaded ports, it is recommended that thread seal tape (Teflon tape) be used. If the suction (intake) connection is not sealed correctly the pump will not prime properly and will pump only small volumes of water or no water at all.
3. Suction and discharge lines should be independently supported at a point near the pump to avoid strains being placed on the pump.
4. It is advisable to install a union in both the suction and discharge lines in the event the pump needs servicing or removal.
5. Before starting the pump for the first time remove the clear lid at the front of the pump. Fill the pump strainer with water until it is level with the suction port opening. Replace the lid making sure the lid is tight Hand tighten only.
6. **BONDING:** as required by the National Electrical Code Article 680-26 the pump must be electrically bonded to the pool structure by a solid copper conductor no smaller than #8 AWG via the external copper bonding lug on the motor.
7. **GROUNDING:** Permanently ground the pump motor using a conductor of appropriate size. Connect to the green headed screw provided inside the motor terminal box.

NOTE DO NOT CONNECT MOTOR TO THE ELECTRIC POWER SUPPLY UNTIL IT IS PERMANENTLY GROUNDED.

PUMP MAINTENANCE

- The pump requires little to no maintenance other than reasonable care and cleaning of the strainer basket on a regular basis. The pump is equipped with a mechanical seal. This seal may eventually come loose of a period of time, depending on running time and water quality. If water continually leaks out, a new mechanical seal should be installed.
- The pump is equipped with a rubber gasket that seals the strainer basket lid. This gasket should be lubricated with water proof lubricant (O-RING LUBE) to ensure proper seal and extend gasket life. The gasket becomes cracked or worn (flattened) is will become necessary to replace.

WINTERIZATION

- In areas subject to freezing temperatures, it is recommended that the pump be disconnected and stored indoors in a warm and dry location. Remove the drain plugs from the pump housing and place them in the strainer basket for storage.

DO NO BLOCK SUCTION

1. Pump suction is dangerous and can trap and drown or disembowel bathers.
2. Blocking suction with body may cause severe and/or fatal injury
3. Do not operate swimming pools, spas or hot tubs if a suction outlet cover is missing, broken or loose
4. Suction outlet must be replaced if cracked, broken or missing.
5. All suction outlets must have correctly installed screw fastened covers in place.



WARNING

RISK OF ELECTRICAL SHOCK

1. To avoid dangerous or fatal electrical shock, **TURN OFF** power to motor **BEFORE** working on electrical connections.
2. To reduce the risk of electrical shock, turn off circuit breaker before working on pump or motor.

TROUBLE SHOOTING GUIDE

PROBLEM	POSSIBLE CAUSE	SOLUTION
Pump will not Prime	Suction Air Leak	<p>Make sure see thru lid and gasket are clean, lubed and tightened. Tighten all hoses and pipes on the suction side of the pump.</p> <p>Be sure water level in the swimming pool is high enough to flow through skimmer. Be sure skimmer port is not plugged or blocked.</p>
	No Water in Pump	<p>Make sure strainer tank is full of water</p>
	Closed Valves or Blocked Lines	<p>Open all valves in system. Clean skimmer and strainer basket. Check for blockage in impeller</p>
	Low Voltage to Motor	<p>Check voltage at motor. If low, pump will not come up to speed</p>
Motor Does Not Run	No Power to Motor	<p>Check that all power switches are on. Be sure fuse or circuit breaker is properly set. Timer set correctly? Check motor wiring at terminals</p>
	Pump Jammed	<p>With power off, turn motor shaft. It should spin freely. If not disassemble and repair</p>
Low Flow	Dirty Filter	<p>Backwash filter. When pressure is high you must backwash or clean filter</p> <p>Clean skimmer basket. Clean pump basket</p>
	Suction Air Leak	<p>See above</p>
	Closed Valve	<p>See above</p>
Motor Runs Hot	<p>Motor is designed to run hot to the touch, this is normal. They are equipped with a thermal overload protector which will turn the motor off if there is an overload or high temperature problem. Excessive heat can be caused by:</p>	
	Poor Ventilation	<p>Do not enclose motor, be sure to have a proper air space around motor</p>
	Installed in direct sun	<p>Shield motor from sun's rays</p>