

PRESSURIZED CARTRIDGE FILTER & BLACK DIAMOND SYSTEMS

FOR ABOVEGROUND AND INGROUND POOLS

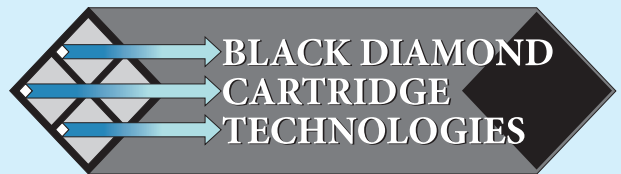
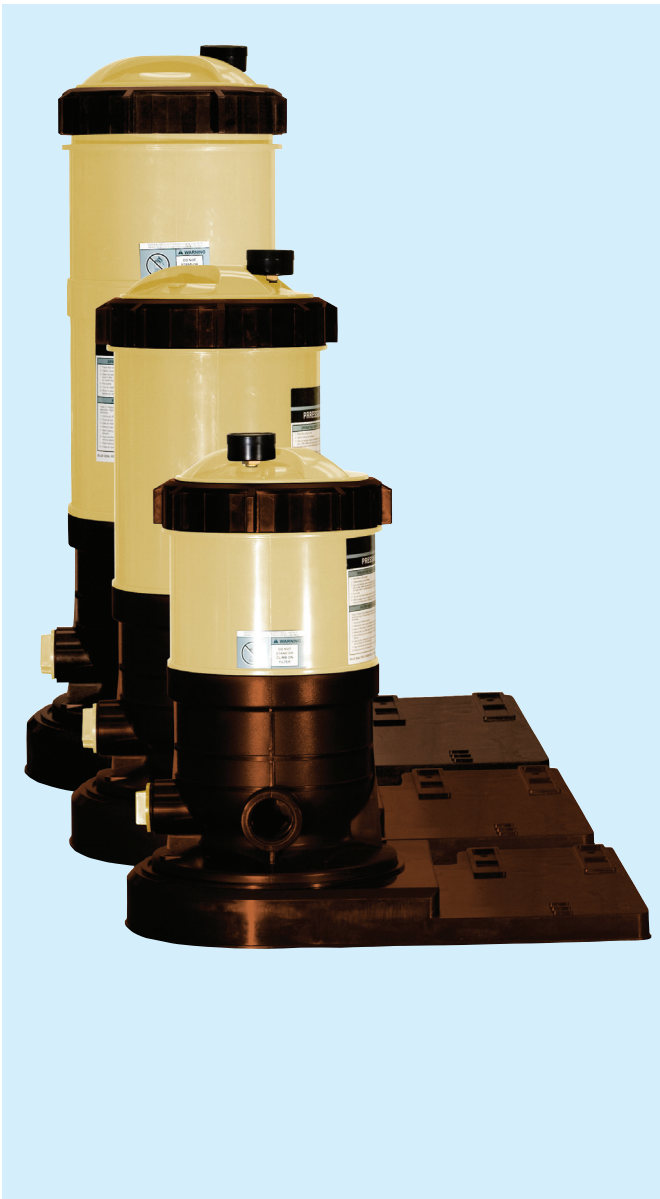

TOOLS REQUIRED

1. Flat Head Screwdriver
2. Pliers

PRESSURIZED CARTRIDGE FILTER & BLACK DIAMOND PARTS

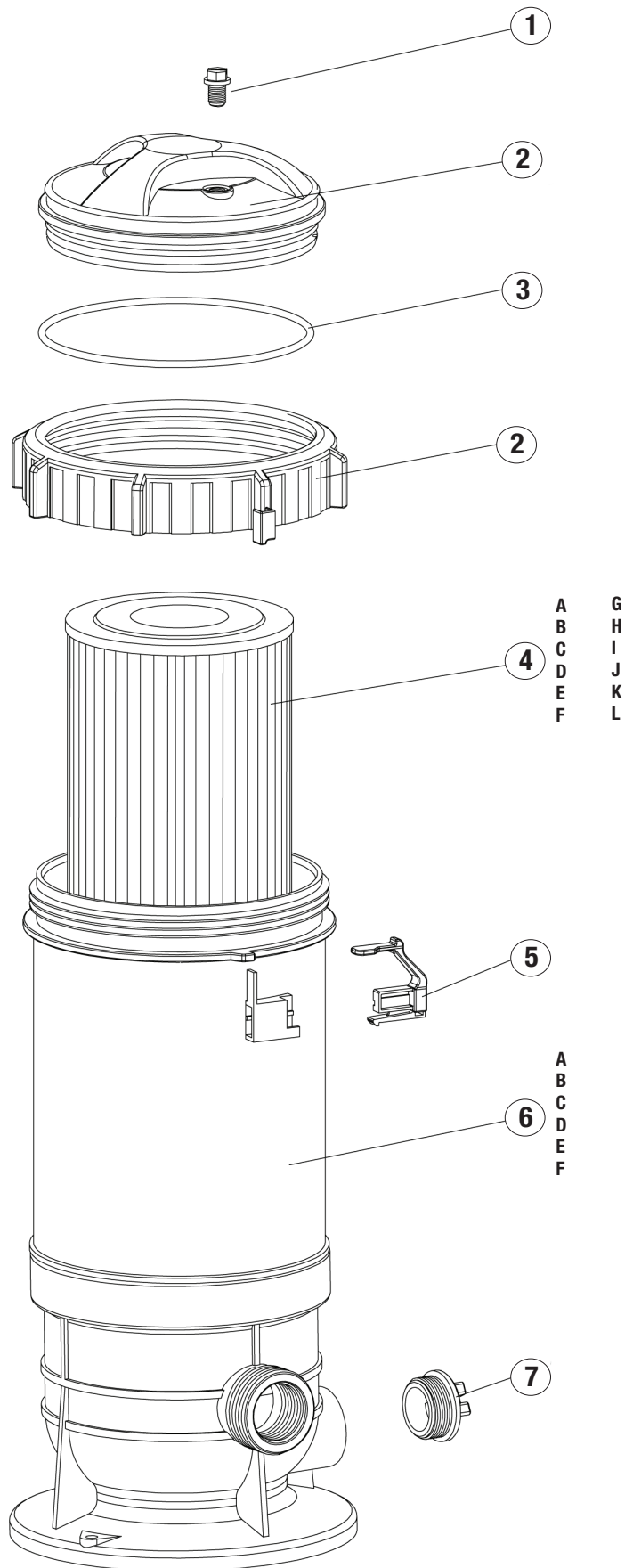

PRESSURIZED CARTRIDGE FILTER & BLACK DIAMOND PARTS

PART #	MODEL #	DESCRIPTION	QTY
1	AC 26913	Bleeder Valve	1
2	AC 26875	Lid	1
3	AC 26883	Lid O-Ring	1
4A	AC 16411	Black Diamond Element 30	1
4B	AC 16497	Black Diamond Element 60	1
4C	AC 16543	Black Diamond Element 90	1
4D	AC 16888	Black Diamond Element 120	1
4E	AC 16985	Black Diamond Element 150	1
4F	AC 17108	Black Diamond Element 180	1
4G	BS 00477	PRC 30 Pressurized Cartridge	1
4H	BS 55387	PRC 60 Pressurized Cartridge	1
4I	BS 55956	PRC 90 Pressurized Cartridge	1
4J	BS 55336	PRC 120 Pressurized Cartridge	1
4K	BS 08753	PRC 150 Pressurized Cartridge	1
4L	BS 08788	PRC 180 Pressurized Cartridge	1
5	AC 61123	Filter Head Latch	1
6A	AC 09474	PRC & Black Diamond Body 30	1
6B	AC 09644	PRC & Black Diamond Body 60	1
6C	AC 09687	PRC & Black Diamond Body 90	1
6D	AC 15873	PRC & Black Diamond Body 120	1
6E	AC 15903	PRC & Black Diamond Body 150	1
6F	AC 16314	PRC & Black Diamond Body 180	1
7	BS 17396GRY	Threaded Plug	1

BLACK DIAMOND EXCLUSIVES BELOW

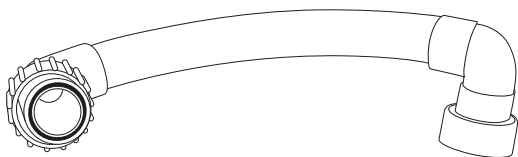

**MOLDED HOSE WITH ADAPTER
FITTING WITH O-RING** AC 04723
UNION ADAPTER AC 08524
O-RING AC 70262

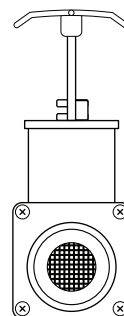

**SLIDE
VALVE**
AC 26859

3. PRE-ASSEMBLY

Hooking up the filter and motor to the base will vary based on the style of pump you have. Please note that steps 4A, 4B, or 4C will help you determine the style of pump and proper hook-up to the base.

Prior to attaching the filter or pump to the base, locate one of the slide valves (I). Cover threads of slide valve entirely with Teflon tape (F) to protect from leaks at the connection. Thread slide valve into the opening marked "TO POOL" on tank, which is the lower open port on the filter (see Figure 1).

The slide valves will enable you to stop the flow of water to the filter when performing routine maintenance, like cleaning your cartridge. The location of the second slide valve will vary based on the style of pump you have. Directions for the installation of this valve will be found in steps 4A, 4B, or 4C. Directions for how to use the slide valves are located in section 6 USING SLIDE VALVES.

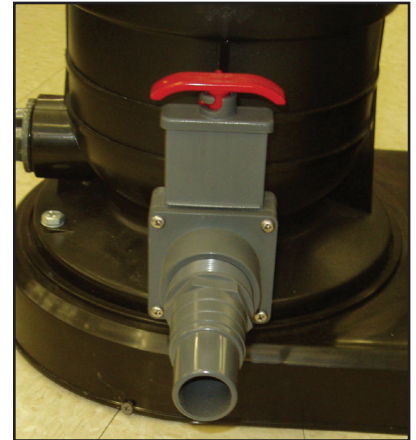
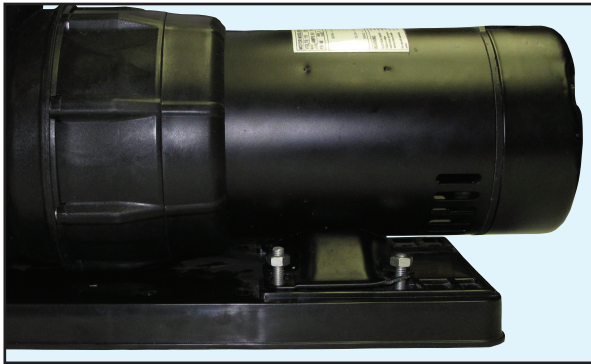

Figure 1 – Slide valve attached "TO POOL" on tank

Included with Black Diamond Models Only

4. ATTACHING PUMP TO BASE & FILTER

As mentioned in the pre-assembly, there are different styles of mounts which will affect the way your pump is attached to the base. Inspect your pump and determine which of the three mounts below is most similar to yours. Use the corresponding directions for your hook-up (4A, 4B or 4C) and then proceed to step 5. Leave motor bolts loose until Union AC 119911 is completely tight.



4A – Cradle style mount pump



4B – Plastic pump housing mount

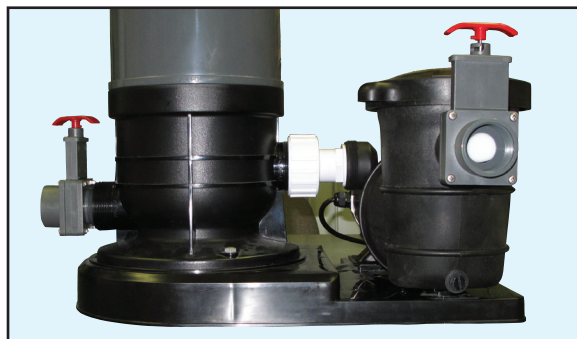

4C – Side mount pump

4A. CRADLE STYLE MOUNT

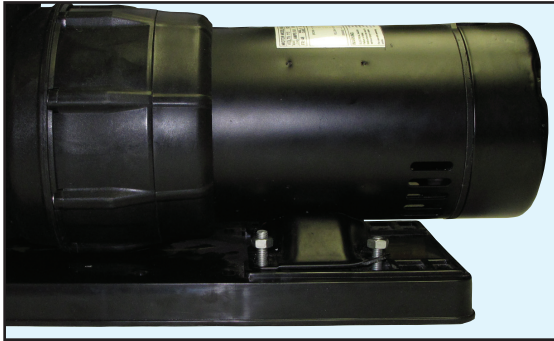

Pumps with cradles located directly under the motor (see Figure 2) should be aligned with the holes inside the raised area of the base (see Figure 3a). This type of mount will require the use of either two or four mounting bolts from the hardware bag (H). Leave motor bolts loose until Union AC 119911 is completely tight.

Figure 2 — Cradle style mount pump



Figure 3b — Pump with slide valve in pump inlet

Cover threads of slide valve entirely with Teflon tape (F) to protect from leaks at the connection. Thread the slide valve into the FRONT of the pump or pump strainer basket if applicable (see Figure 3b).

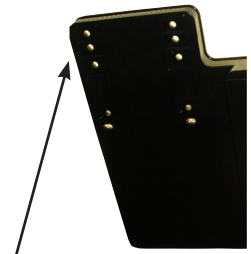

Figure 3a — Raised area on base



Figure 4 — Slide valve installed in bottom of skimmer

If there are NO THREADS on the inside of your pump inlet or on the inside of the pump basket, attach slide valve to the bottom of your thru-wall skimmer (in place of standard fitting). This valve will allow you to stop the flow of water FROM the pool in the event of filter maintenance (see Figure 4).

Attach Standard Fitting from skimmer to female end of Slide Valve.

For Inground pool installations the Slide Valve is optional (since filter is above the water level) Slide Valve can be installed at any union joint between skimmer and pump intake.

Black Diamond Models Only

Place tank on top of round opening on base and rotate until the holes in the tank bottom line up with the holes in the base. Use the remaining mounting bolts from hardware bag (H) to secure in place. BEFORE bolting down, make sure that the port labeled "TO PUMP" (open port, without slide valve) is facing the back of the base (longer part of base indicates back). See Figures 5 and 6 below.

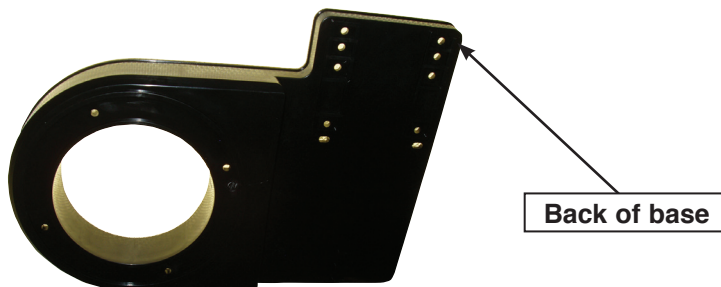

Figure 5 — Back of base



Figure 6
Filter on base

PROCEED TO STEP 5

4B. PLASTIC PUMP HOUSING MOUNT

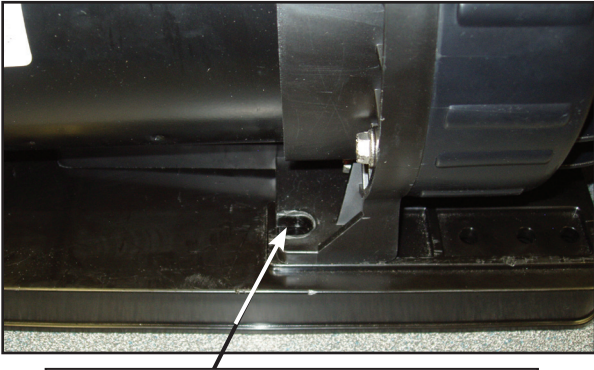

Figure 7 — Plastic pump housing mount

- Pumps with plastic pump housing mounts (see Figure 7) should be attached by aligning the openings with the holes outside the raised area (see Figure 8A). This type of mount will require the use of TWO mounting bolts from the hardware bag (H).
- Please note that there are TWO sets of openings. Some pumps will need to be connected to the first set and others will need to be bolted down through the second set.
- If you are attaching the Speck E90 (SS E90) pump to the base, use the set of holes *closest to the raised area*.
- If you are attaching the Speck E91 or E92 (SS E91 or SS E92) pump, use the set of holes that are *closest to the center of the base*.

- Failure to follow these placement instructions will result in an issue connecting the flex pipe with connection fittings to the pump and filter.



Figure 8b — Pump with slide valve in pump inlet

Cover threads of slide valve entirely with Teflon tape (F) to protect from leaks at the connection. Thread the slide valve into the FRONT of the pump or pump strainer basket if applicable (see Figure 8b).



Figure 8a — Holes outside raised area



Figure 9 — Slide valve installed in bottom of skimmer

If there are NO THREADS on the inside of your pump inlet or on the inside of the pump basket, attach to bottom of thru-wall skimmer (in place of standard fitting). This valve will allow you to stop the flow of water FROM the pool in the event of filter maintenance (see Figure 9).

Attach Standard Fitting from skimmer to female end of Slide Valve.

Black Diamond Models Only

For Inground pool the installation of the Slide valve is optional. Slide valve can be installed at any union joint between the pool's return jets and the filters "to pool" port.

Place tank on top of round opening on base and rotate until the holes in the tank bottom line up with the holes in the base. Use remaining mounting bolts from hardware bag (H) to secure in place. BEFORE bolting down, make sure that the port labeled "TO PUMP" (open port, without slide valve) is facing the back of the base (longer part of base indicates back). See Figures 10 and 11.



Figure 10 — Back of base

Back of base

Figure 11 — Filter on base



PROCEED TO STEP 5

4C. SIDE-MOUNT PUMPS



Figure 12 – Side mount pump

Side-mount pumps (see Figure 12) allow you to attach the pump DIRECTLY to the filter body. Prior to attaching the pump, you must attach the tank to the base in order to determine which set of holes to use for the pump.

Slide Valve Black Diamond Models Only

Place tank on top of round opening on base and rotate until the holes in the tank bottom line up with the holes in the base. Use remaining mounting bolts from hardware bag (H) to secure in place. BEFORE bolting down, make sure that the port labeled “TO PUMP” (open port, without slide valve) is facing towards motor mount.

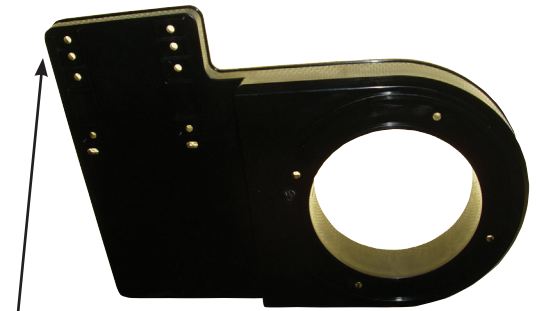

Figure 13a – Raised area of the base

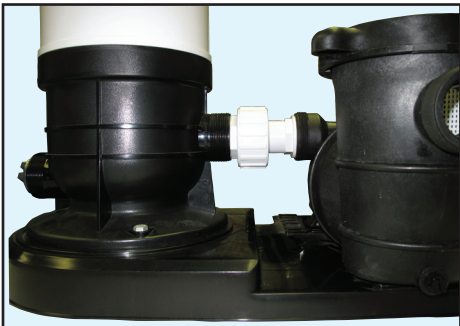

Figure 13b – Side mount pump attached directly the filter tank

Attach Side Mount Union (K) to pump by using Teflon tape on threads and screwing into the pump opening. When properly installed, the 2” locking ring should face the filter body. Place the pump onto the raised part of the base (see Figure 13a) and line up with the set of holes which allows the union to line up with the “TO PUMP” filter port. Use the mounting bolts to secure on base (see Figure 13b). Leave motor bolt loose until Union is completely tight.

Thread the ring of the union onto the threads on the outside of the “TO PUMP” port. Once this is secure, cover threads of slide valve entirely with Teflon tape (F) to protect from leaks at the connection. Thread the slide valve into the FRONT of the pump or pump strainer basket if applicable (see Figure 14).



Figure 14 – Pump with slide valve in pump inlet

Black Diamond Models Only



Figure 15 – Slide valve installed in bottom of skimmer

If there are NO THREADS on the inside of your pump inlet or on the inside of the pump basket, attach to bottom of thru-wall skimmer (in place of standard fitting). This valve will allow you to stop the flow of water FROM the pool in the event of filter maintenance (see Figure 15).

Attach Standard Fitting from skimmer to female end of Slide Valve.

For Inground pool installations the Slide Valve is optional (since filter is above the water level) Slide Valve can be installed at any union joint between skimmer and pump intake.

5. ATTACHING FITTINGS & HOSES TO YOUR PUMP & FILTER

There are several ways to hook up hoses to your filter and pump and the best way will depend on your set-up. Some pumps have female threads only (inside), some have male threads only (outside) and others may have both or none. There are parts included in CARTON 2 which will allow for set-up with virtually any style of pump. Below are the options available for hook-up based on the threads that your pump has.



Figure 16 — Fitting threaded into slide valve

First, cover the threads on the straight fitting **(G)** and thread it into the slide valve which you have attached to the filter's "TO POOL" opening (see Figure 16). Attach the 6' hose **(B)** to the fitting you just threaded in and clamp in place using hose clamp **(D)**. The free end of this hose should be attached to the thru wall return using another hose clamp (see Figure 17).



Figure 17 — Free end of hose attached to return

For Inground pool the installation of the Slide valve is optional. Slide valve can be installed at any union joint between the pool's return jets and the filters "to pool" port.



Figure 18a

There should be at least one hose fitting provided with your pump (or that you may need to purchase separately), which you will thread into the second slide valve which has been threaded into the bottom of your skimmer OR into your pump (see Figure 18a & 18b). Cover the threads of that fitting with Teflon tape before screwing it into the opening on the second slide valve.



Figure 18b

Slide Valve Black
Diamond Models Only

Black Diamond Models Only

For Inground installations the pump intake port Slide Valve is optional and can be installed at any union joint between the pump intake port and the pools skimmers.

Now it's time to attach the flex pipe with connection fittings **(C)** to your filter and pump. Keep in mind that the hose is bent so that the pump will accept the 'higher' part and the filter will accept the 'lower' part of the connection. Check the flex pipe with connection fittings to ensure that O-Rings are inside (see Figure 19). Lubricate O-Ring with O-Ring Lube (sold separately) prior to installation.

NOTE: If you have a SIDE-MOUNT PUMP, you will NOT need to attach this piece to your filter as the pump is already connected.



Figure 19 — O Ring for flex pipe connection fitting

NOTE: If you have a pump that has **NO THREADS** then you will need to purchase additional items to set up your new filter system. You will need to get a 3' hose (1-1/4" or 1-1/2" depending on the size your pump accepts) to attach directly onto your pump's outlet as the threaded fitting provided will not fit and *an elbow fitting is necessary* to thread into the female threads in the filter "FROM PUMP" port to attach your hose. Please remember you will need additional *hose clamps* to install with this method (see Figure 20).



Figure 20 — Hooking up to pump with no threads



Figure 21 — Attaching flex pipe to filter

If your pump has threads on the **outside** of the outlet (top of the pump) then you will thread one of the connection fittings directly onto it. Thread opposite side directly onto the "FROM PUMP" port of the filter and hand tighten connection (see Figures 21 & 22).

If your pump **ONLY** has threads on the **inside** of the outlet (top of the pump) then you will need to use the union adapter (**J**). Cover the male threads of the union adapter with Teflon tape and thread the union adapter directly into the outlet on the pump. At this point you may thread one of the connection fittings directly onto the union adapter and the other onto the "FROM PUMP" port of the filter and hand tighten the connection (see Figures 21 & 22).

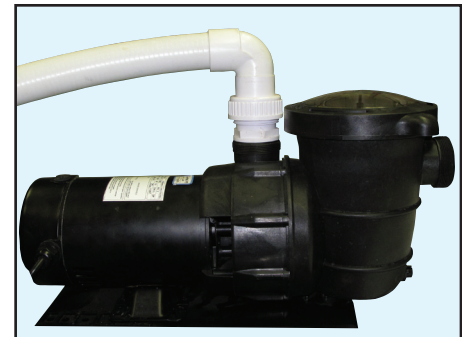

Figure 22 — Attaching flex pipe to pump



Figure 23a — Hose attached to thru wall skimmer with valve

Finally, attach second 6' filter hose (**B**) using clamps (**D**) to the fitting on the bottom of your thru wall skimmer and the other end onto the front of your pump (see Figure 23a and 23b). Once clamped in place you are done installing the filter system.

For Inground pool installations the Slide Valve is optional (since filter is above the water level) Slide Valve can be installed at any union joint between skimmer and pump intake.



Figure 23b — Hose attached to thru wall skimmer

Black Diamond Models Only

6. USING SLIDE VALVES

The slide valves are used to stop the flow of water to the filter for routine maintenance. While the filter is in operation, the slide valves **MUST** remain in the open position. To open the valve, turn the red handle to the left and pull straight up (see Figure 23a for open valve).

When you need to clean the cartridge you will have to move the slide valves into the closed position. First, turn off your pump to avoid damage due to excessive pressure. Next, push the red handle straight down and turn it to the left to lock valve in place (see Figure 24).

Remember to open BOTH valves again prior to restarting pump after cleaning. Failure to do so will result in damage to your Filter System.



Figure 24 — Slide valve in closed position

Black Diamond Models Only

Make sure that the cartridge is installed inside the filter body, the lid O-Ring is lubricated and the lid is closed securely. The pressure gauge (**E**) should be screwed into the opening on the tank lid after covering the threads with Teflon tape. (See Figures 25a & 25b).

The O-Ring has been factory installed.

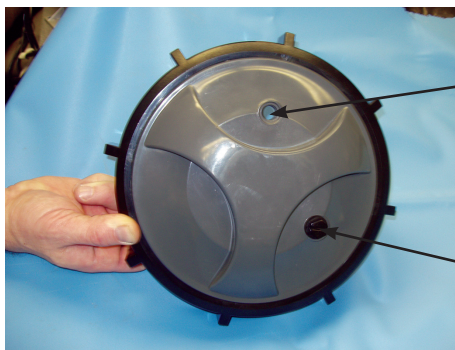

Figure 25a — Filter Lid

Opening for pressure gauge

Air relief valve



Figure 25b — Installing pressure gauge

Fill the water in the pool to the middle of your thru-wall skimmer BEFORE operating your filter. Once water has reached mid-skimmer you may turn on the pump. You **MUST** bleed the air out of the system using the air relief valve on top of the tank (see Figure 25a). Turn the valve to the left, you will hear a hiss of air and once all the air is cleared some water will spurt out. Close the valve and the filter is ready to operate.

READ AND FOLLOW SAFETY INSTRUCTIONS



This is the safety alert symbol. When you see this symbol on your system or in this manual, look for one of the following signal words and be alert to the potential for personal injury.

! DANGER

Warns about hazards that will cause death, serious personal injury, or major property damage if ignored.

! WARNING

Warns about hazards that can cause death, serious personal injury, or major property damage if ignored.

! CAUTION

Warns about hazards that will or can cause minor personal injury or property damage if ignored.

NOTICE

Indicates special instructions not related to hazards.

CAREFULLY READ AND FOLLOW ALL SAFETY INSTRUCTIONS IN THIS MANUAL AND ON EQUIPMENT
Keep safety labels in good condition; replace if missing or damaged.

! WARNING

Incorrectly installed or tested equipment may fail, causing severe injury or property damage.

Hazardous Pressure

Read and follow instructions in owner's manual when installing and operating equipment.

1. Do not connect system to a high pressure or city water system..
2. Use equipment only for a pool installation
3. Trapped air in system can cause explosion. BE SURE all air is out of system before operating or testing equipment.

BEFORE OPERATING, MAKE THE FOLLOWING SAFETY CHECKS

1. Check all clamps, bolts, lids and system accessories before testing.
2. Release all air in system before testing.
3. Tighten trap lids.
4. Water pressure must be less than 25 PSI (172 kPa).
5. Water temperature must be less than 100° F. (38° C).
6. Open all slide valves.

! DANGER	BEFORE WORKING ON FILTER:
If filter clamp is adjusted under pressure, tank will blow off base, causing severe injury or major property damage.	<ol style="list-style-type: none"> 1. Stop pump. 2. Open air release valve. 3. Release all pressure from system.

GENERAL INFORMATION

⚠ DANGER

Hazardous pressure. Permanent Filter damage will result if Filter is improperly dis-assembled or assembled. To avoid danger of severe injury or major property damage, always follow service instructions in this manual (Pages 11 to 13) when working on filter.

⚠ WARNING

Risk of injury. Never operate this filter system at more than 50 pounds per square inch (50 PSI/345kPa) pressure!

- Clean a new pool as well as possible before filling pool and operating filter.
- Excess dirt and large particles of foreign matter in the system can cause serious damage to the filter and pump.
- With a cartridge filter system in place and operating correctly, clean water is returned to the pool faster than the pool water is being contaminated. A typical pool installation will require approximately one week to obtain and maintain the sparkle that your filter is capable of giving you.
- Keep pool water pH at recommended level (7.2 to 7.6).
- Be sure both clamps are in place and knobs are securely tightened before starting filter.
- Maintain pressure gauge in good working order. Replace gauge if it fails or is damaged.

NOTICE

Some pool disinfectants may clog filter media. To maximize media life and filter cycle time, closely follow disinfectant manufacturer's instructions when cleaning pool or filter.

POOL CHEMISTRY GUIDELINES

SUGGESTED POOL CHEMISTRY LEVELS	ACTION REQUIRED TO CORRECT POOL CHEMISTRY	
	TO RAISE	TO LOWER
pH 7.2 to 7.6	Add pH UP	Add pH DOWN
TOTAL ALKALINITY 100 to 130 ppm	Alkalinity Up	Add pH DOWN
CHLORINE (Unstabilized) 0.3 to 1.0 ppm	Add Chlorine Chemical	No action - Chlorine will naturally dissipate
CHLORINE (Stabilized) 1.0 to 3.0 ppm	Add Chlorine Chemical	No action - Chlorine will naturally dissipate
CHLORINE STABILIZER (Cyanuric Acid) 40 to 70 ppm	Add Stabilizer (Cyanuric Acid)	Dilution — partially drain & refill pool with water that has not been treated with Cyanuric

INSTALLATION — GENERAL

FILTER LOCATION SHOULD:

- Provide space and lighting for easy access for routine maintenance.
- Provide adequate ventilation and drainage for pump.
- Be reasonably level.
- Be as close to pool as possible to reduce line loss from pipe friction.

PIPING

- Never use pipe joint sealing compound on pipe and fittings that are plastic or may come into contact with plastic. To seal threaded connections on PVC pipe and fittings, use only teflon tape. Pipe joint compound may cause stress cracking of plastic components.

NOTICE

Filter locations remote from pool are possible but may require larger pipe to produce adequate flow through filter.

- Check local codes if considering a remote installation.
- Fittings restrict flow; for best efficiency use fewest possible fittings.
- Keep piping tight and free of leaks. Pump suction line leaks may cause trapped air in filter tank or loss of prime at pump. Pump discharge line leaks may show up as dampness or jets of water.

VALVES

- A check valve installed between pool and filter outlet will prevent contaminants from draining back into pool.

NOTICE

A check valve between filter and pool will also prevent possible back flow which could dislocate element from its seat.

- A check valve installed between filter and heater will prevent hot water from heater from backing up into the filter and deforming filter elements.

NOTICE

Damaging filter elements through excessive heat voids the warranty.

ELECTRICAL

- **BE SURE** filter grounding and bonding meets local and National Electrical Code standards. All wiring, grounding and bonding of associated equipment must also meet local and National Electrical Code standards.

ASSEMBLING FILTER

Filter Cartridge may shift position during shipping. To make sure cartridge is in place, follow procedure below before using filter.

When disassembling filter, place all parts in a clean area.

1. Place filter in a clean area near its permanent location.
2. Remove filter lid by turning Locking Ring counter clockwise Figure 1. Remove clamp by lifting straight up over tank.
3. As clamp is turned the Filter lid will rise from the tank body. Please note the Filter Lid and Locking Ring are one piece.
4. Set tank lid in a clean place; check for missing or damaged parts.
5. Filter element should be installed firmly by pressing into base.
6. Replace tank lid evenly on filter tank shell for a tight seal.

NOTICE Be sure O-Ring and O-Ring seating area are clean.

7. Replace Filter lid and Locking Ring assembly on tank. Make sure lid flange is centered and placed inside center port of cartridge.

NOTICE To properly engage threads make sure Filter lid is on straight and push downward.

8. Tighten Locking Ring by turning clockwise until it stops Hand Tighten Only. Locking tab will engage.
9. Attach pressure gauge and air release valve as shown in Figure 1. Apply Teflon tape to threads of pressure gauge.

NOTICE Tighten gauge hand tight only. Tighten air release valve finger tight only.

CONNECTING FILTER PIPING

NOTICE For ease of installation, plastic pipe and fittings are recommended for all piping to and from pool. DO NOT use pipe joint compound on base of filter. To do so will cause stress cracking of base, which will void warranty and may cause property damage.

CAUTION Risk of damage to filter. Do not tighten fittings into base ports past thread stops. To do so will ruin filter base and void warranty, and may cause property damage.

NOTICE If pool water level is higher than filter base, shut-off valves must be installed in suction and return lines.

1. Wrap 1-1/2 to 2 layers of teflon tape to male threads only on all piping and fittings.
2. Hand tighten fitting in each port. Be careful not to cross thread.
3. Tighten fittings to a snug fit with wrench. Be careful not to thread fittings past thread stop.
4. If pipe connections leak, remove teflon tape, re-apply teflon tape and re-tighten in ports. Do not overtighten.

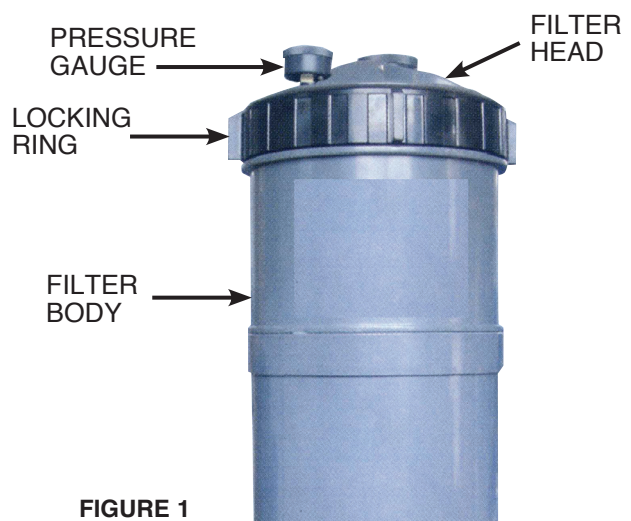

FIGURE 1

START UP

WARNING

1. Turn pump OFF before starting procedure.
2. Properly seat filter clamps and securely tighten clamp knobs before proceeding.

NOTICE

1. Tightly close plugs on Tank Drain Port (Figure 2).
2. Open air release valve located on top of filter tank lid.

NOTICE

Air trapped inside the filter greatly increases the tank pressure. The air release valve allows you to get accumulated air out of the filter tank. At startup, open the air release valve and make sure that it is running a solid stream of water before putting the filter in service.

1. Start pump.
2. When a steady stream of water comes from air release valve, close valve.
3. After filter is operating, record filter pressure gauge reading in owner's manual for future use.

NOTICE

When installed on a new pool, filter element may need cleaning after approximately 48 hours of operation.

NOTICE

A new or recently cleaned filter element may pass some foreign material until it builds up a sufficient coating to stop all "fines". This is normal. A short operational period will correct the condition.

Check pressure gauge. If pressure has risen more than 10 PSI (70kPa) above startup pressure, remove and clean element.

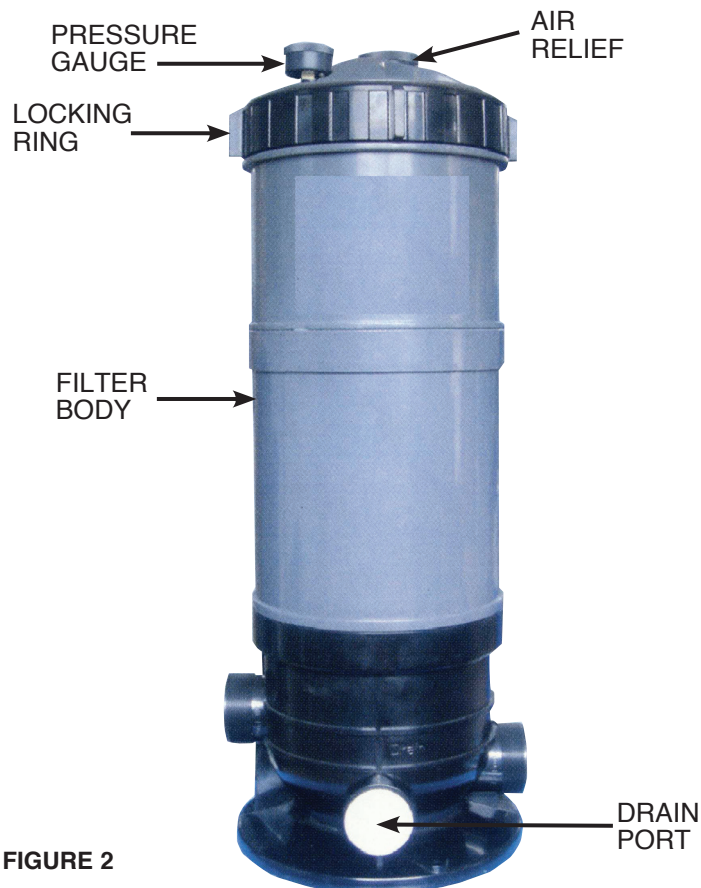

FIGURE 2

FILTER DISASSEMBLY

DANGER

Hazardous Pressure

Releasing lid ring with pressure on system will cause tank or tank lid to blow off base, causing severe injury or property damage. NEVER adjust, tighten or loosen ring when tank is under pressure. If filter leaks at the ring, do not adjust the ring. Instead, follow instructions under "Filter Disassembly", below and "Filter Assembly", Page 8.



Regularly inspect clamp assemblies for cracked, corroded or broken welds and worn or stripped threads. If any wear or damage shows, replace the complete ring.



Tension stresses and aggressive pool chemicals can aggravate mechanical wear. Tank clamp assemblies and nuts or plastic knobs should be replaced every five years.



Do not use a filter that shows cracks, corrosion or distortion.

FILTER DISASSEMBLY

1. STOP PUMP.

2. **CLOSE** suction and return line valves (if used).

3. **OPEN** air release valve on top of filter.

4. **WAIT** until all pressure is released from filter tank and system before loosening either clamp.



WARNING To prevent injury, make sure that all pressure has been released from filter tank BEFORE proceeding.

5. Remove drain plug or open drain valve at "Tank Drain Port" and drain filter.

6. Loosen lid ring; remove clamp by lifting it straight up over tank.

7. Remove tank lid from tank body. Be careful not to damage O-Ring. Place tank lid in clean area.

NOTICE

If heavy dirt deposits have collected around bottom of filter element and base, wash out base before removing element.

8. Remove the O-Ring from the filter. Clean the O-Ring and inspect it. If you see cuts, cracking, deformation or wear, replace it.

9. Rock filter element to one side to free seal.

10. Lift element out of tank body. Do not drop filter element. Place element in clean area where it can be cleaned with hose and spray nozzle attachment.

FILTER REASSEMBLY

1. Replace plugs or close valves in Tank Drain and Auxiliary Drain ports.
2. Set filter element on base.
3. Make sure filter element is flush with base of filter to avoid damaging element when you replace the filter lid (Figure 3).
4. Inspect and clean the tank flanges and O-Ring seats. If flanges are deformed, cracked or corroded, replace entire filter.
5. Re-install Filter Head and Locking Ring assembly on tank.
6. Tighten Locking Ring by turning clockwise until it stops. Hand Tighten Only.
7. Clean pump strainer basket.
8. Open system valves as needed.
9. Proceed to "Startup".

LIFT FILTER ELEMENT
STRAIGHT UPWARD
TO REMOVE

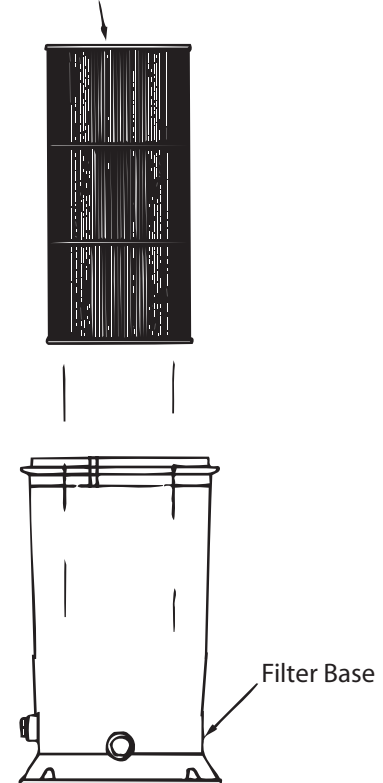

FIGURE 3

FILTER CLEANING PROCEDURE

NOTICE

Keep track of filter operating pressure. When pressure reaches 10 pounds per square inch (PSI) (70kPa) above initial operating pressure, clean filter element.

NOTICE

If filter is used with a spa, soak element (see Step 2, "Special Cleaning Instructions") at each regular cleaning. With hose, wash foreign material from inside of base. Try to avoid washing debris into outlet port (See figure 4)

NOTICE

Be sure inside surface of base is clean.

WASHING FILTER ELEMENT (See Figures 4, 5 and 6)

1. Use a garden hose with straight flow nozzle to wash down filter element (Figure 4). For best results use a spray nozzle cleaning system.
2. Work from the top down; wash down all pleats. Wash between all pleats.
3. Turn element while spraying to wash down entire outside of element.
4. Repeat wash down process for inside of filter element. Hold nozzle as close to inside of pleats as possible (Figure 6).

NOTICE

- BE SURE all dirt and foreign materials are washed away from INSIDE pleats of element.
- TIP — Have a second cartridge on hand and ready to use; this will avoid filter down time.

SPECIAL CLEANING INSTRUCTIONS

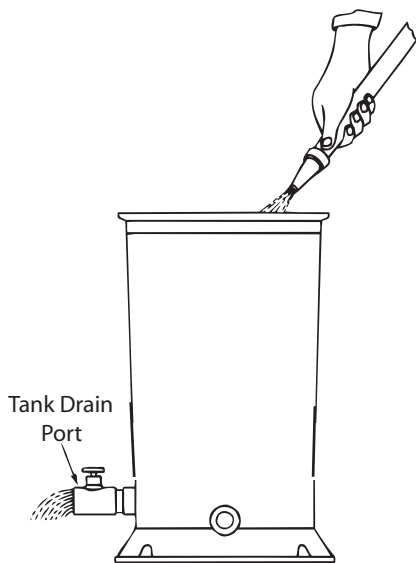

FIGURE 4



FIGURE 5

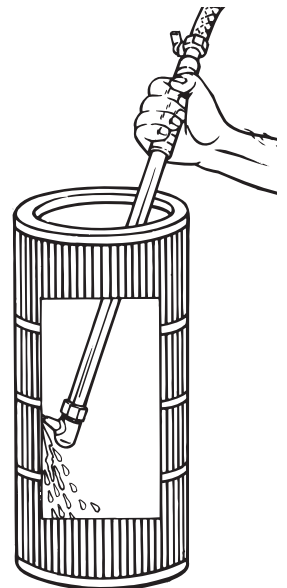

FIGURE 6

NOTICE

Some pool disinfectants may clog filter media. To maximize media life and filter cycle time, closely follow disinfectant manufacturer's instructions when cleaning pool or filter.

For stubborn deposits, proceed as follows:

1. Follow Filter Cleaning Procedure (Page 9).
2. If deposits remain, soak element at least one hour with a solution of Filter Flush and water.
3. Wash off with water to remove oils, dirt and remaining cleaner solution.
4. If filter element does not come clean with this procedure, consult your pool professional. Acid washing should be done only by trained professionals who have proper safety equipment and acid disposal facilities.

WINTERIZING

NOTICE Filter must be protected from the weather and drained if freezing is anticipated. Allowing filter to freeze can cause damage to filter and WILL VOID THE WARRANTY!

1. Stop pump.
2. Open air release valve.
3. Remove drain plugs from ports or open valves at "Tank Drain Ports".
4. Drain ALL piping to and from filter.
 - a) Gravity drain system as far as possible.
 - b) Protect areas which retain water with non-toxic propylene glycol antifreeze (RV antifreeze) or pipeline Anti-Freeze.
5. Turn to Page 7 for filter disassembly instructions.

CAUTION Do not remove or damage safety and instruction labels during cleaning. Replace any decals which may have been damaged.

TROUBLESHOOTING GUIDE

SHORT CYCLE:

NOTICE Time between cleanings will vary with each installation. The following causes and remedies are for cycle times shorter than normal.

NOTICE Some pool disinfectants may clog filter media. To maximize media life and filter cycle time, closely follow disinfectant manufacturer's instructions when cleaning pool or filter.

POSSIBLE CAUSES:

1. Chlorine residual too low — maintain proper residual (consult pool professional for recommendation).
2. Flow rate too high — restrict flow to rated capacity of filter (see instruction decal on filter).
3. Filter too small — install larger filter or additional filter.
4. Unstable water — consult pool professional.
5. Filter element not cleaned properly or plugged with algae, iron, calcium, etc — See "Special Cleaning Instructions".
6. Heavy or improper application of powdered chlorine or chlorine pills that contain a binder — See "Special Cleaning Instructions".
7. Algae in pool — apply heavy dose of chlorine or algaecide as recommended by pool manufacturer. Continue until algae is controlled.

LOW FLOW:

POSSIBLE CAUSES:

1. Element is plugged — see “Special Cleaning Instructions”.
2. Pipe blocked downstream from filter — remove obstruction.
3. Piping too small — replace with larger pipe (consult dealer for recommendation).
4. Pump hair and lint trap is plugged — empty and clean.
5. Pump impeller and diffuser worn — replace with new parts. Consult pump owner’s manual for information.
6. Pump too small for system — replace with larger pump.
7. Pump pulling in air — lube hair and lint trap O-Ring.

POOL WATER NOT CLEAR:

POSSIBLE CAUSES:

1. Chlorine dosage too low — maintain adequate chlorine residual (consult pool professional for recommendation).
2. Element cloth torn or punctured — replace element.
3. Filter too small, flow too low, or daily operating time too short, giving inadequate turnover rate — consult dealer to verify that equipment is properly sized for your pool.
4. Pump too large — overpumping — reduce flow rate.
5. Filter installed backward — replumb.

LONG RECOVERY TIME AFTER HEAVY USAGE:

POSSIBLE CAUSES:

1. Residual Chlorine level is too low — add chlorine.
2. Filter too small — replace with larger unit.
3. Pump too large — reduce flow rate.

FILTER BY-PASSES DIRT:

POSSIBLE CAUSES:

1. Element cloth torn or punctured — replace element.
2. Filter element is not seated properly in filter base — follow instructions under “Filter Disassembly - Reassembly” and reposition properly.
3. Filter is plumbed backwards and element cloth is ruptured — replumb properly and replace element.
4. Colloidal fines (very small suspended dirt particles) are present and passing through element covering — use Crystal Clear or if fines have already settled, vacuum to waste.
5. Blue bypass plug was removed from lid — replace bypass plug and lid.